



I

切斷刀架 Grooving

內徑端面刀識別系統 Carbide End Mill Identification System.....	I02
內徑切斷刀識別系統 Various Icons Guide And Processing Icon Guide	I02
內徑開槽刀架 Internal Grooving	外徑端面淺槽切斷刀架 External Shallow Grooving
ECZ	EHH
HOZR	I03
ECDG	I12
I04	內徑出水端面淺槽刀架 External Shallow Grooving
I05	NEW HOSR
外徑切斷刀架 External Grooving	I13
EZH	外徑淺槽刀架 External Slot Grooving
EGHGR	EWC
ETGDR	I14
EDGTR	外徑切斷刀板 Blade For Parting Off
EDGH	EIH
EGYH	EBU
EGEHR	I15
I20	I15
端面刀架 Face Grooving	
NEW HOGR	I08-I09
EZG	I10-I11

內徑端面刀識別系統

Boring Bar Face Grooving Identification System

EOGR 25M-29 35-3T 12



1 2 3 4 5 6 7 8

1 材質 Grade 2 出水說明 Coolant System 3 型式代碼 Grooving Type 4 進刀變換 Version 5 柄徑 Shank Dia 6 加工範圍 Bore Dia(Mini~Max)

1 材質 Grade 2 出水說明 Coolant System 3 型式代碼 Grooving Type 4 進刀變換 Version 7 加工寬度 Insert Processing width

記號 Sign	材質說明 Material	記號 Sign	說明 Description
E	一般材質 Normal Material	O	出水式 With Coolant
H	模具鋼 Alloy Tool Steel	C	無出水式 Without Coolant

記號 Sign	代碼說明 Type Description
G	端面刀 Face Grooving
S	端面淺槽刀 Shallow Grooving

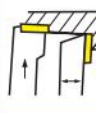
記號 Sign	方向 Direction
R	
N	
L	

7 加工寬度
Insert Processing width

8 加工深度
Insert Processing Depth

7 加工寬度 Insert Processing width

記號 Sign	加工寬度 (mm) Insert Processing Width	記號 Sign	加工寬度 (mm) Insert Processing Width
2T	2.0 mm	4T	4.0 mm
3T	3.0 mm	5T	5.0 mm

內徑切斷刀識別系統

Boring Bar Slotting Tool Identification System

EOZR 25-2 M-A



1 2 3 4 5 6 7 8

1 材質 Grade 2 出水說明 Coolant System 3 型式代碼 Grooving Type 4 進刀變換 Version 5 柄徑 Shank Dia 6 加工寬度 Insert Processing Width

1 材質 Grade 2 出水說明 Coolant System 3 型式代碼 Grooving Type 4 進刀變換 Version 7 總長 Over All Length

記號 Sign	材質說明 Material	記號 Sign	說明 Description
E	一般材質 Normal Material	O	出水式 With Coolant
H	模具鋼 Alloy Tool Steel	C	無出水式 Without Coolant

記號 Sign	代碼說明 Type Description
Z	開槽刀 Slotting Tool

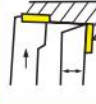
記號 Sign	方向 Direction
R	
N	
L	

8 刀架型式
Shank Type

7 加工寬度 Insert Processing width

記號 Sign	加工寬度 (mm) Insert Processing Width	記號 Sign	加工寬度 (mm) Insert Processing Width
2T	2.0 mm	4T	4.0 mm
3T	3.0 mm	5T	5.0 mm

ECZ

新規格上市
New Specification Arrival

本圖所示為右手刀(R)
Right Hand Show

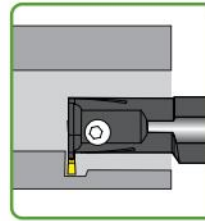
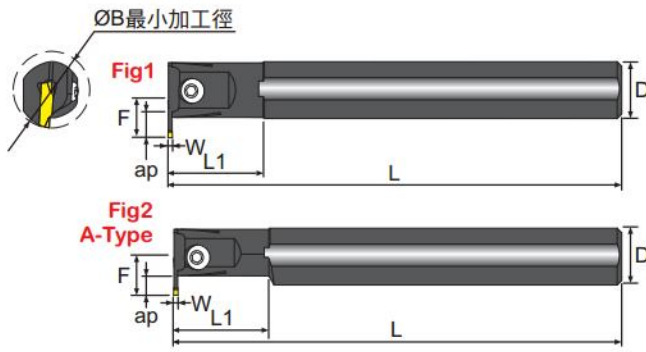

材質 Shank	產品型號 Model No	在庫 Stock		加工徑 Min. Bore Dia. ØB	圖解 Fig	寸法 Dimension(mm)						刀片 Insert	螺絲 Screw	L型板手 Wrench	價格 Price
		R	L			ap	D	F	L	L1	W				
S	ECZR/L-20-2M-A	●	●	24	2	5	20	13	180	32	2	ECH200	CD6-60	LW040	
	ECZR/L-20-3M-A	●	●	24	2	5	20	13	180	32	3	ECH300			
	ECZR/L-25-2M-A	●	●	31	2	8	25	17	200	42	2	ECH200			
	ECZR/L-25-2M	●	●	35	1	8	25	21	200	42	2	ECH200			
	ECZR/L-25-3M-A	●	●	31	2	8	25	17	200	42	3	ECH300			
	ECZR/L-25-3M	●	●	35	1	8	25	22	200	42	3	ECH300			
	ECZR/L-25-4M-A	●	●	31	2	8	25	17	200	42	4	ECH400			
	ECZR/L-25-4M	●	●	35	1	8	25	21	200	42	4	ECH400			
	NEW ECZR/L-25-5M	●	●	35	1	10	25	22.5	200	42	5	ECH500			
	ECZR/L-32-3M-A	●	●	39	2	10	32	22	250	54	3	ECH300	CD6-60-20		
	ECZR/L-32-3M	●	●	43	1	10	32	26	250	54	3	ECH300			
	ECZR/L-32-4M-A	●	●	39	2	10	32	22	250	54	4	ECH400			
	ECZR/L-32-4M	●	●	43	1	10	32	26	250	54	4	ECH400			
	ECZR/L-40-3M	●	●	55	1	13	40	32	300	80	3	ECH300			
	ECZR/L-40-4M	●	●	55	1	13	40	32	300	80	4	ECH400			
ECZR/L-40-5M	●	●	55	1	13	40	32	300	80	5	ECH500				
ECZR/L-50-3M	●	●	65	1	14	50	38	350	100	3	ECH300				
ECZR/L-50-4M	●	●	65	1	14	50	38	350	100	4	ECH400				
ECZR/L-50-5M	●	●	65	1	14	50	38	350	100	5	ECH500				

●刀片資料：ECH→參考A42頁
●Insert Detail：ECH→Ref.Page-A42

HOZR 本圖所示為右手刀 (R)
Right Hand Show

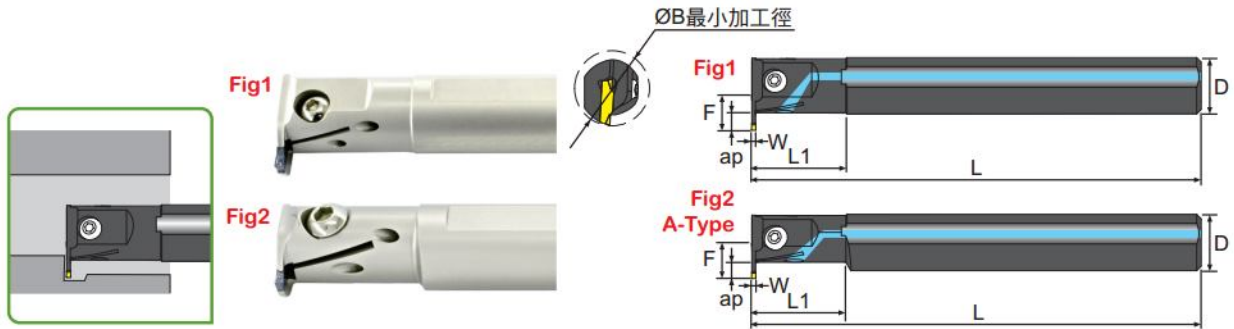

材質 Shank	產品型號 Model No	在庫 Stock		加工徑 Min. Bore Dia. ØB	圖解 Fig	寸法 Dimension(mm)						刀片 Insert	螺絲 Screw	L型板手 Wrench	價格 Price	
		R	L			ap	D	F	L	L1	W					
H	HOZR/L-20-2M-A			24	2	5	20	13	180	32	2	ECH200	CD6-60			
	HOZR/L-20-3M-A			24	2	5	20	13	180	32	3					ECH300
	HOZR/L-25-2M-A			31	2	8	25	17	200	42	2					
	HOZR/L-25-2M			35	1	8	25	21	200	42	2					ECH300
	HOZR/L-25-3M-A			31	2	8	25	17	200	42	3					
	HOZR/L-25-3M			35	1	8	25	22	200	42	3					ECH400
	HOZR/L-25-4M-A			31	2	8	25	17	200	42	4					
	HOZR/L-25-4M			35	1	8	25	21	200	42	4					ECH300
	HOZR/L-32-3M-A			39	2	10	32	22	250	54	3	ECH300				
	HOZR/L-32-3M			43	1	10	32	26	250	54	3		ECH400			
	HOZR/L-32-4M-A			39	2	10	32	22	250	54	4	ECH400				
	HOZR/L-32-4M			43	1	10	32	26	250	54	4		ECH300	CD6-60-20		
	HOZR/L-40-3M			55	1	13	40	32	300	80	3	ECH300				
	HOZR/L-40-4M			55	1	13	40	32	300	80	4				ECH400	
	HOZR/L-40-5M			55	1	13	40	32	300	80	5	ECH300				
	HOZR/L-50-3M			65	1	14	50	38	350	100	3		ECH300			
	HOZR/L-50-4M			65	1	14	50	38	350	100	4			ECH400		
	HOZR/L-50-5M			65	1	14	50	38	350	100	5	ECH500				

●刀片資料：ECH→參考A42頁
●Insert Detail：ECH→Ref.Page-A42

ECDG 本圖所示為右手刀 (R)
Right Hand Show

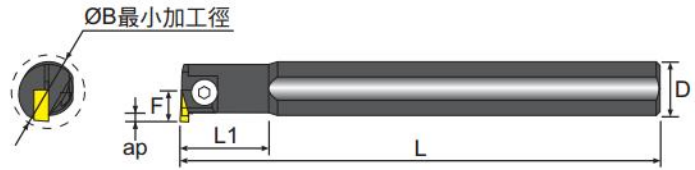
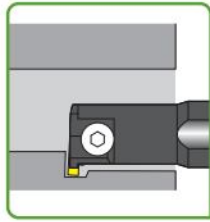

材質 Shank	產品型號 Model No	在庫 Stock		加工徑 Min. Bore Dia. ØB	寸法 Dimension(mm)					刀片 Insert	螺絲 Screw	L型板手 Wrench	價格 Price
		R	L		ap	D	F	L	L1				
S	ECDGR/L-20-3M	●	●	24	5	20	13	150	32	DGM30	CD6-60	LW040	
	ECDGR/L-25-3M	●	●	31	8	25	17	200	40				
	ECDGR/L-32-3M		●	39	10	32	22	250	50		CD6-60-20		

- 刀片：三菱。
- Insert：Mitsubishi.

EZH

新規格上市
New Specification Arrival

本圖所示為右手刀 (R)
Right Hand Show

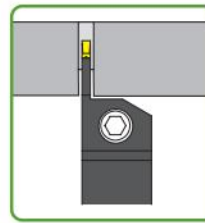
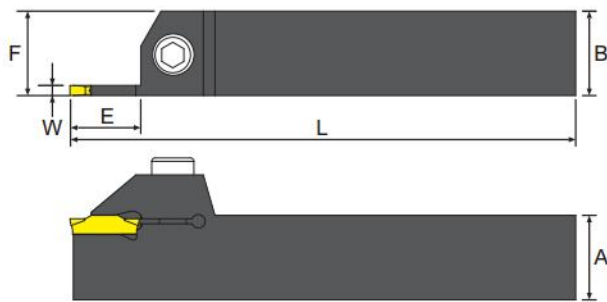

材質 Shank	產品型號 Model No	在庫 Stock		圖解 Fig	寸法 Dimension(mm)						刀片 Insert	螺絲 Screw	L型板手 Wrench	價格 Price
		R	L		A	B	E	F	L	W				
H	EZHR/L-10K-2D-14	●	●	1	10	10	14	10	125	2	ECH200	CS35115	T15	
	EZHR/L-10K-3D-14	●	●	1	10	10	14	10	125	3	ECH300			
	EZHR/L-12K-2D-14	●	●	1	12	12	14	12	125	2	ECH200			
	EZHR/L-12K-3D-14	●	●	1	12	12	14	12	125	3	ECH300			
	EZHR/L-16K-2D-14	●	●	1	16	16	14	16	125	2	ECH200	CS6-50	LW040	
	EZHR/L-16K-3D-16	●	●	1	16	16	16	16	125	3	ECH300			
S	EZHR/L-20K-2D-14	●	●	2	20	20	14	20	125	2	ECH200	CS6-60	LW050	
	EZHR/L-20K-3D-20	●	●	2	20	20	20	20	125	3	ECH300			
	EZHR/L-20K-3D-25	●	●	2	20	20	25	20	125	3	ECH300			
	EZHR/L-20K-4D-20	●	●	2	20	20	20	20	125	4	ECH400			
	EZHR/L-20K-4D-25	●	●	2	20	20	25	20	125	4	ECH400			
	EZHR/L-25M-2D-06	●		2	25	25	6	25	150	2	ECH200			
	EZHR/L-25M-2D-09	●		2	25	25	9	25	150	2				
	EZHR/L-25M-2D-14	●	●	2	25	25	14	25	150	2				
	EZHR/L-25M-2D-17	●		2	25	25	17	25	150	2				
	EZHR/L-25M-3D-09	●	●	2	25	25	9	25	150	3	ECH300			
	EZHR/L-25M-3D-20	●	●	2	25	25	20	25	150	3				
	EZHR/L-25M-3D-25	●	●	2	25	25	25	25	150	3				
	EZHR/L-25M-4D-09	●	●	2	25	25	9	25	150	4	ECH400			
	EZHR/L-25M-4D-20	●	●	2	25	25	20	25	150	4				
	EZHR/L-25M-4D-25	●	●	2	25	25	25	25	150	4				
EZHR/L-25M-5D-09	●		2	25	25	9	25	150	5					

※ 請接下頁。 ※ Continued on next page.

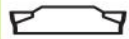

材質 Shank	產品型號 Model No	在庫 Stock		圖解 Fig	寸法 Dimension(mm)						刀片 Insert 	螺絲 Screw 	L型扳手 Wrench 	價格 Price
		R	L		A	B	E	F	L	W				
S	EZHR/L-25M-5D-25	●	●	2	25	25	25	25	150	5	ECH500	CS6-60	LW050	
	EZHR/L-25M-6D-20	●	●	2	25	25	20	25	150	6	ECH600			
	EZHR/L-25M-6D-25	●	●	2	25	25	25	25	150	6	ECH600			
H	HZHR/L-20K-2D-14	●		2	20	20	14	20	125	2	ECH200	CS6-60	LW050	
	HZHR/L-20K-3D-20	●		2	20	20	20	20	125	3	ECH300			
	HZHR/L-20K-3D-25	●		2	20	20	25	20	125	3	ECH300			
	HZHR/L-20K-4D-20	●		2	20	20	20	20	125	4	ECH400			
	HZHR/L-20K-4D-25	●		2	20	20	25	20	125	4	ECH400			
	HZHR/L-25M-2D-14	●		2	25	25	14	25	150	2	ECH200			
	HZHR/L-25M-3D-20	●		2	25	25	20	25	150	3	ECH300			
	HZHR/L-25M-3D-25	●		2	25	25	25	25	150	3	ECH300			
	HZHR/L-25M-4D-20	●		2	25	25	20	25	150	4	ECH400			
	HZHR/L-25M-4D-25	●		2	25	25	25	25	150	4	ECH400			
	HZHR/L-25M-5D-30	●		2	25	25	30	25	150	5	ECH500			

●刀片資料：ECH→參考A42頁

●Insert Detail：ECH→Ref.Page-A42

HOGR 新品上市

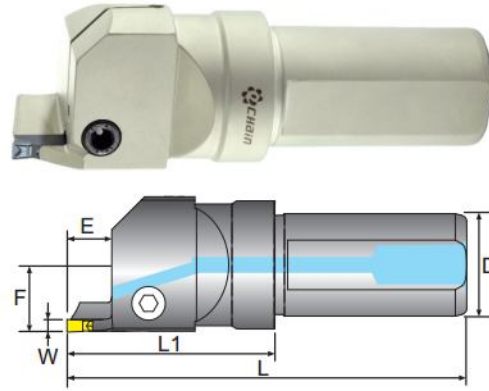
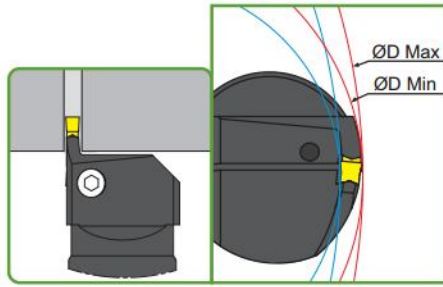

產品型號 Model No	在庫 Stock	加工範圍 Range ØD		寸法 Dimension(mm)						刀片 Insert	螺絲 Screw	L型板手 Wrench	價格 Price
		Max	Min	D	E	F	L	L1	W				
HOGR32M-2934-4T14	●	29	34	32	14	21	125	65	4	ECH400	CS6-60	LW050	
HOGR32M-2934-4T25	●	29	34	32	25	21	125	65	4				
HOGR32M-2935-3T12		29	35	32	12	21	125	65	3	ECH300			
HOGR32M-2935-3T20		29	35	32	20	21	125	65	3				
HOGR32M-3540-3T12		35	40	32	12	21	125	65	3				
HOGR32M-3540-3T20		35	40	32	20	21	125	65	3				
HOGR32M-4050-3T12		40	50	32	12	21	125	65	3				
HOGR32M-4050-3T20		40	50	32	20	21	125	65	3				
HOGR32M-4050-4T14		40	50	32	14	21	125	65	4	ECH400			
HOGR32M-4050-4T25		40	50	32	25	21	125	65	4				
HOGR32M-4050-5T14		40	50	32	14	21	125	65	5	ECH500			
HOGR32M-4050-5T25	●	40	50	32	25	21	125	65	5				
HOGR32M-5060-3T12		50	60	32	12	21	125	65	3	ECH300			
HOGR32M-5060-3T20	●	50	60	32	20	21	125	65	3				
HOGR32M-5060-4T14		50	60	32	14	21	125	65	4	ECH400			
HOGR32M-5060-4T25		50	60	32	25	21	125	65	4				
HOGR32M-5060-5T14		50	60	32	14	21	125	65	5	ECH500			
HOGR32M-5060-5T25		50	60	32	25	21	125	65	5				
HOGR32M-6075-3T12		60	75	32	12	21	125	65	3	ECH300			
HOGR32M-6075-3T20		60	75	32	20	21	125	65	3				
HOGR32M-6085-4T14	●	60	85	32	14	21	125	65	4	ECH400			

※ 請接下頁。 ※ Continued on next page.



產品型號 Model No	在庫 Stock	加工範圍 Range ØD		寸法 Dimension(mm)						刀片 Insert	螺絲 Screw	L型扳手 Wrench	價格 Price
		Max	Min	D	E	F	L	L1	W				
HOGR32M-6085-4T25	●	60	85	32	25	21	125	65	4	ECH400	CS6-60	LW050	
HOGR32M-6085-5T14	●	60	85	32	14	21	125	65	5	ECH500			
HOGR32M-6085-5T25	●	60	85	32	25	21	125	65	5	ECH500			
HOGR32M-75100-3T12		75	100	32	12	21	125	65	3	ECH300			
HOGR32M-75100-3T20		75	100	32	20	21	125	65	3	ECH300			
HOGR32M-85125-4T14		85	125	32	14	21	125	65	4	ECH400			
HOGR32M-85125-4T25		85	125	32	25	21	125	65	4	ECH400			
HOGR32M-85125-5T14	●	85	125	32	14	21	125	65	5	ECH500			
HOGR32M-85125-5T25	●	85	125	32	25	21	125	65	5	ECH500			
HOGR32M-100150-3T12		100	150	32	12	21	125	65	3	ECH300			
HOGR32M-100150-3T20		100	150	32	20	21	125	65	3	ECH300			
HOGR32M-125200-4T14		125	200	32	14	21	125	65	4	ECH400			
HOGR32M-125200-4T25		125	200	32	25	21	125	65	4	ECH400			
HOGR32M-125200-5T14		125	200	32	14	21	125	65	5	ECH500			
HOGR32M-125200-5T25		125	200	32	25	21	125	65	5	ECH500			
HOGR32M-135200-3T12		135	200	32	12	21	125	65	3	ECH300			
HOGR32M-135200-3T20		135	200	32	20	21	125	65	3	ECH300			
HOGR32M-180250-3T12		180	250	32	12	21	125	65	3	ECH300			
HOGR32M-180250-3T20		180	250	32	20	21	125	65	3	ECH300			
HOGR32M-180280-4T14		180	280	32	14	21	125	65	4	ECH400			
HOGR32M-180280-4T25		180	280	32	25	21	125	65	4	ECH400			
HOGR32M-180280-5T14		180	280	32	14	21	125	65	5	ECH500			
HOGR32M-180280-5T25		180	280	32	25	21	125	65	5	ECH500			
HOGR32M-250999-4T14		250	999	32	14	21	125	65	4	ECH400			
HOGR32M-250999-4T25		250	999	32	25	21	125	65	4	ECH400			
HOGR32M-250999-5T14		250	999	32	14	21	125	65	5	ECH500			
HOGR32M-250999-5T25		250	999	32	20	21	125	65	5	ECH500			

●刀片資料：ECH→參考A42頁

●Insert Detail：ECH→Ref.Page-A42

EZG  **新規格上市**
New Specification Arrival

本圖所示為右手刀 (R)
Right Hand Show

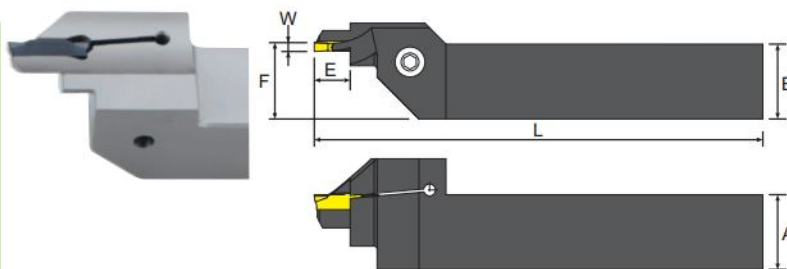
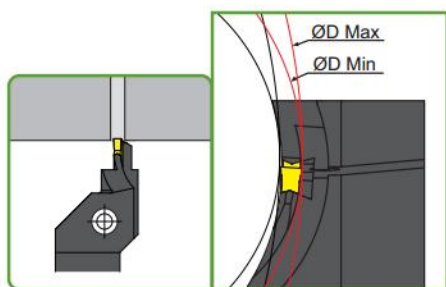

產品型號 Model No	在庫 Stock	加工範圍 Range ØD		寸法 Dimension(mm)						刀片 Insert	螺絲 Screw	L型扳手 Wrench	價格 Price			
		Max	Min	A	B	E	F	L	W							
EZGR-2520-2934-4T17	●	34	29	25	25	17	26	150	4	ECH400	CS6-60	LW050				
EZGR-25-2934-4T06	●	34	29	25	25	6	26	150	4							
EZGR-25-2934-4T09	●	34	29	25	25	9	26	150	4							
EZGR-25-2934-4T12	●	34	29	25	25	12	26	150	4							
EZGR-25-2934-4T14	●	34	29	25	25	14	26	150	4							
EZGR-25-2934-4T17	●	34	29	25	25	17	26	150	4							
EZGR-25-2934-4T20	●	34	29	25	25	20	26	150	4							
EZGR-25-2934-4T25	●	34	29	25	25	25	26	150	4							
EZGR-25-2935-3T12	●	35	29	25	25	12	26	150	3	ECH300						
EZGR-25-3540-3T12	●	40	35	25	25	12	26	150	3							
EZGR-25-4050-3T12	●	50	40	25	25	12	26	150	3							
EZGR-25-4050-4T14	●	50	40	25	25	14	26	150	4	ECH400						
EZGR-25-4050-5T14	●	50	40	25	25	14	26	150	5	ECH500						
EZGR-25-5060-3T12	●	60	50	25	25	12	26	150	3	ECH300						
EZGR-25-5060-4T14	●	60	50	25	25	14	26	150	4	ECH400						
EZGR-25-6075-3T12	●	75	60	25	25	12	26	150	3	ECH300						
EZGR-25-6075-3T20	●	75	60	25	25	20	26	150	3							
EZGR-25-6085-4T14	●	85	60	25	25	14	26	150	4	ECH400						
EZGR-25-6085-4T25	●	85	60	25	25	25	26	150	4							
EZGR-25-6085-5T14	●	85	60	25	25	14	26	150	5	ECH500						
EZGR-25-6085-5T25	●	85	60	25	25	25	26	150	5							
EZGR-25-75100-3T12	●	100	75	25	25	12	26	150	3	ECH300						

※ 請接下頁。 ※ Continued on next page.

產品型號 Model No	在庫 Stock	加工範圍 Range ØD		寸法 Dimension(mm)						刀片 Insert 	螺絲 Screw 	L型扳手 Wrench 	價格 Price
		Max	Min	A	B	E	F	L	W				
EZGR-25-75100-3T20	●	100	75	25	25	20	26	150	3	ECH300	CS6-60	LW050	
EZGR-25-85125-4T14	●	125	85	25	25	14	26	150	4	ECH400			
EZGR-25-85125-4T25	●	125	85	25	25	25	26	150	4	ECH400			
EZGR-25-85125-5T14	●	125	85	25	25	14	26	150	5	ECH500			
EZGR-25-85125-5T25	●	125	85	25	25	25	26	150	5	ECH500			
NEW EZGR-25-85125-5T30	●	125	85	25	25	30	26	150	5	ECH500			
EZGR-25-100150-3T12	●	150	100	25	25	12	26	150	3	ECH300			
EZGR-25-100150-3T20	●	150	100	25	25	20	26	150	3	ECH300			
EZGR-25-125200-4T14	●	200	125	25	25	14	26	150	4	ECH400			
EZGR-25-125200-4T25	●	200	125	25	25	25	26	150	4	ECH400			
EZGR-25-125200-5T14	●	200	125	25	25	14	26	150	5	ECH500			
EZGR-25-125200-5T25	●	200	125	25	25	25	26	150	5	ECH500			
EZGR-25-135200-3T12	●	200	135	25	25	12	26	150	3	ECH300			
EZGR-25-135200-3T20	●	200	135	25	25	20	26	150	3	ECH300			
EZGR-25-180250-3T12	●	250	180	25	25	12	26	150	3	ECH300			
EZGR-25-180250-3T20	●	250	180	25	25	20	26	150	3	ECH300			
EZGR-25-180250-4T14	●	280	180	25	25	14	26	150	4	ECH400			
EZGR-25-180280-4T25	●	280	180	25	25	25	26	150	4	ECH400			
EZGR-25-180280-5T14	●	280	180	25	25	14	26	150	5	ECH500			
EZGR-25-180280-5T25	●	280	180	25	25	25	26	150	5	ECH500			
EZGR-25-250999-4T14	●	999	250	25	25	14	26	150	4	ECH400			
EZGR-25-250999-4T25	●	999	250	25	25	25	26	150	4	ECH400			
EZGR-25-250999-5T14	●	999	250	25	25	14	26	150	5	ECH500			
EZGR-25-250999-5T25	●	999	250	25	25	25	26	150	5	ECH500			

●刀片資料：ECH→參考A42頁
 ●Insert Detail：ECH→Ref.Page-A42

EHH 本圖所示為右手刀 (R)
Right Hand Show

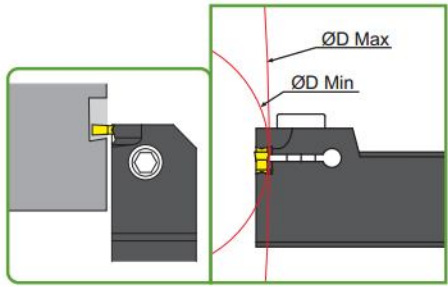

產品型號 Model No	在庫 Stock		加工範圍 Range ØD		寸法 Dimension(mm)						刀片 Insert	螺絲 Screw	L型扳手 Wrench	價格 Price
	R	L	Max	Min	A	B	E	F	L	W				
EHHR/L-20K-2D-6	●		1000	350	20	20	6	20	125	2	ECH200	CS6-60	LW050	
EHHR/L-20K-3D-6	●	●	1000	110	20	20	6	20	125	3	ECH300			
EHHR/L-20K-4D-6	●	●	1000	80	20	20	6	20	125	4	ECH400			
EHHR/L-25M-2D-6	●		1000	350	25	25	6	25	150	2	ECH200			
EHHR/L-25M-3D-6	●	●	1000	110	25	25	6	25	150	3	ECH300			
EHHR/L-25M-4D-6	●	●	1000	80	25	25	6	25	150	4	ECH400			
EHHR/L-25M-5D-8	●	●	1000	90	25	25	8	25	150	5	ECH500			

●刀片資料：ECH→參考A42頁
●Insert Detail：ECH→Ref.Page-A42

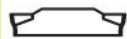

HOSR **新品上市**
New Arrival

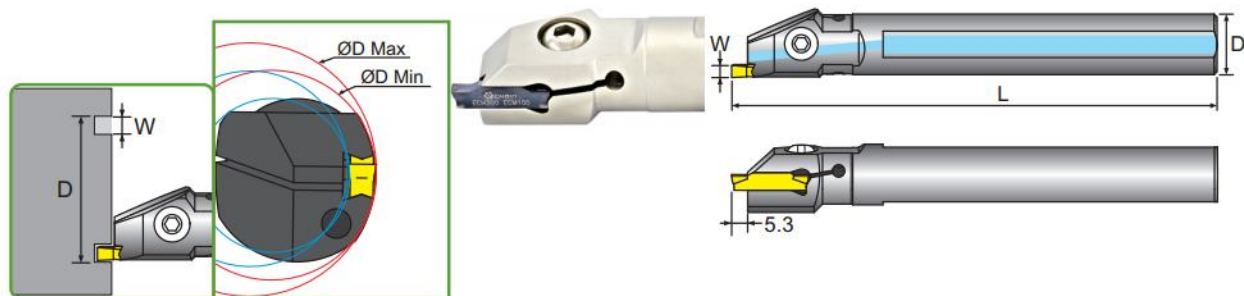

產品型號 Model No	在庫 Stock		加工範圍 Range ØD		寸法 Dimension(mm)			刀片 Insert	螺絲 Screw	L型扳手 Wrench	價格 Price		
	R	L	Max	Min	D	L	W						
NEW HOSR/L20Q-2935-3T5			35	29	20	180	3	ECH300	CS6-60	LW050			
NEW HOSR/L25R-5090-3T5			90	50	25	200	3						
NEW HOSR/L32S-60240-3T5			240	60	32	250	3						
NEW HOSR/L40T-80999-3T5			999	80	40	300	3						
NEW HOSR/L20Q-2935-4T5			35	29	20	180	4	ECH400					
NEW HOSR/L25R-5090-4T5			90	50	25	200	4						
NEW HOSR/L32S-60240-4T5			240	60	32	250	4						
NEW HOSR/L40T-80999-4T5			999	80	40	300	4						
NEW HOSR/L20Q-2935-5T5			35	29	20	180	5	ECH500					
NEW HOSR/L25R-5090-5T5			90	50	25	200	5						
NEW HOSR/L32S-60240-5T5			240	60	32	250	5						
NEW HOSR/L40T-80999-5T5			999	80	40	300	5						

- 刀片資料 : ECH→參考A42頁
- Insert Detail : ECH→Ref.Page-A42

EWC 本圖所示為右手刀 (R)
Right Hand Show

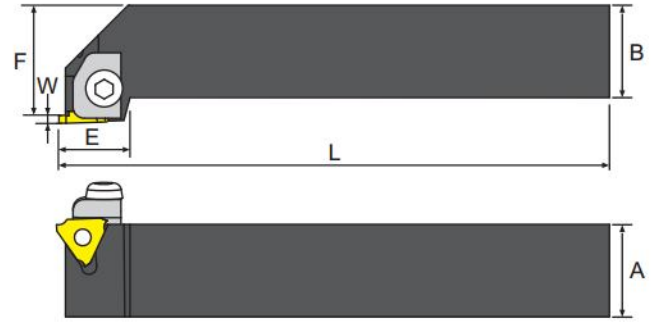
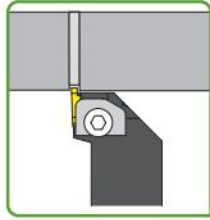

產品型號 Model No	在庫 Stock		寸法 Dimension(mm)					刀片 Insert	螺絲 Screw	壓板 Clamp	螺絲 Screw	彈簧 Spring	旗型板手 Wrench	L型板手 Wrench	價格 Price
	R	L	A	B	E	F	L	W							
EWCR/L-1212K16	●	●	12	12	12	12	125	3	EC16R/L	CH40	-	-	-	-	-
EWCR/L-1616K16	●	●	16	16	16	12	125	3	EC22R/L	CS45	ETK1 R/L	CD6- 60-20	S6	T-15	LW040
EWCR/L-2020K16	●	●	20	20	25	25	125	3							
EWCR/L-2020K22	●	●	20	20	20	25	125	0.5-4.8							
EWCR/L-2020K22-15	●	●	20	20	20	25	125	1.5-2.3							
EWCR/L-2020K22-25	●	●	20	20	20	25	125	2.5-3.3							
EWCR/L-2020K22-35	●	●	20	20	20	25	125	3.5-4.8							
EWCR/L-2525M16	●	●	25	25	25	30	150	3							
EWCR/L-2525M22	●	●	25	25	25	30	150	0.5-4.8							
EWCR/L-2525M22-15	●	●	25	25	25	30	150	1.5-2.3							
EWCR/L-2525M22-25	●	●	25	25	25	30	150	2.5-3.3							
EWCR/L-2525M22-35	●	●	25	25	25	30	150	3.5-4.8							

●刀片資料：EC16R、EC22R→參考A43頁
●Insert Detail：EC16R、EC22R→Ref.Page-A43

ETN3

- ◆ 材質介紹→參考A04頁
Grade Ref.Page-A04
- ◆ 斷削槽選擇→參考A06-A08頁
Chipbreaker Ref.Page-A06-A08
- ◆ 切削條件→參考A09頁
Cutting condition Ref.Page-A09

形狀 Shape	型號 Model No	半徑 R	厚度 S	塗層硬質合金 Carbide Coated
	ETN3-1E	0.3	3	P BEF706

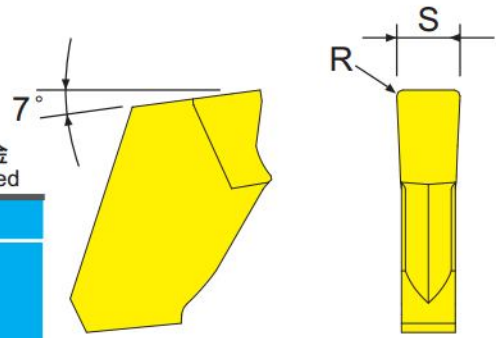

EIH 外徑切斷刀板 Blade For Parting Off

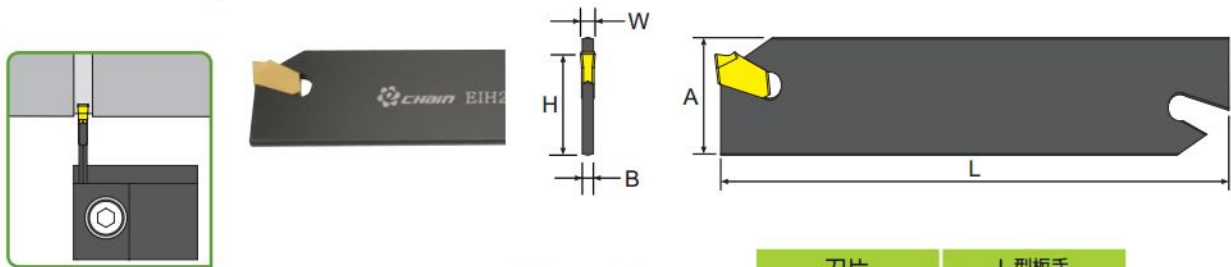

產品型號 Model No	在庫 Stock	寸法 Dimension(mm)					刀片 Insert	L型板手 Wrench	價格 Price
		A	B	H	L	W			
EIH26-3	●	25.4	2.4	21	110	3	ETN3	EL-1	
EIH32-3	●	31.3	2.4	25	150	3			

- 刀片資料：ETN3→參考I15頁
- Insert Detail：ETN3→Ref.Page-I15
- 刀座請參考“EBU”。
- Block refer “EBU” as below.

※EL-1此板手需另外購買。
※EL-1(wrench) isn't included in the holders, it needs to purchase separately.

EBU

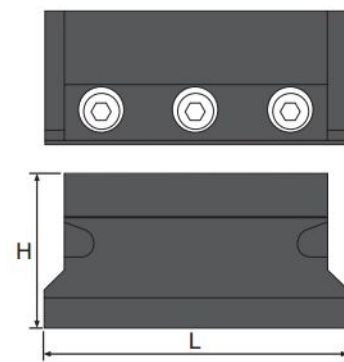
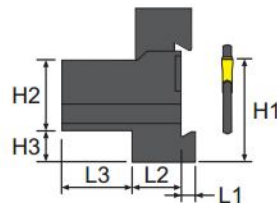

產品型號 Model No	在庫 Stock	寸法 Dimension(mm)					適用刀具 Assembly Holder	螺絲 Screw	L型板手 Wrench	價格 Price
		H	H1	H2	H3	L				
EBU20-26	●	45	20	20	10	80	EIH26-3 EIH32-3	CS6-60	LW050	
EBU20-32	●	50	25	20	13.5	100				
EBU25-32	●	50	25	25	8.5	110				

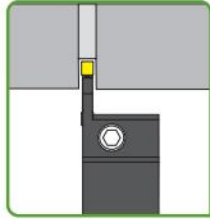
EGHGR 本圖所示為右手刀 (R)
Right Hand Show

外徑深加工霸王刀刀架

Chief Tool Holders for External Deep Grooving.

- 可開槽、擴槽及外徑深加工等。
- 可切斷、修端面。
- Grooving, Broach grooving & deep grooving.
- Cut-off grooving & face grooving.

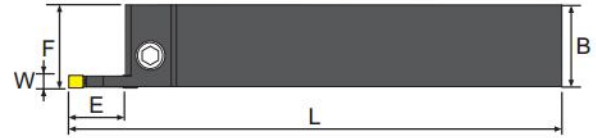

產品型號 Model No	在庫 Stock		寸法 Dimension(mm)						刀片 Insert	螺絲 Screw	L型扳手 Wrench	價格 Price			
	R	L	A	B	E	F	L	W							
EGHGR/L-16-3M	●	●	16	16	16	16	125	3	GIP	CS6-50	LW040				
EGHGR/L-20-2M	●		20	20	14	20	125	2							
EGHGR/L-20-3M	●	●	20	20	20	20	125	3							
EGHGR/L-20-4M	●	●	20	20	20	20	125	4-5							
EGHGR/L-25-2M	●		25	25	14	25	150	2			CS6-60	LW050			
EGHGR/L-25-3M	●	●	25	25	20	25	150	3							
EGHGR/L-25-4M	●	●	25	25	20	25	150	4-5							
EGHGR/L-25-5M	●	●	25	25	25	25	150	5-6.4							
EGHRGR/L-25-5M-20	●		25	25	20	25	150	5							

●刀片：伊斯卡。

●Insert：Iscar.

ETGDR 本圖所示為右手刀 (R)
Right Hand Show

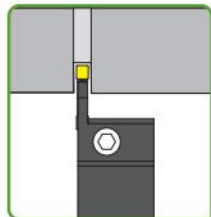

外徑深加工霸王刀刀架

Chief Tool Holders for External Deep Grooving.

- 可開槽、擴槽及外徑深加工等。
- 可切斷、修端面。
- Grooving, Broach grooving & deep grooving.
- Cut-off grooving & face grooving.

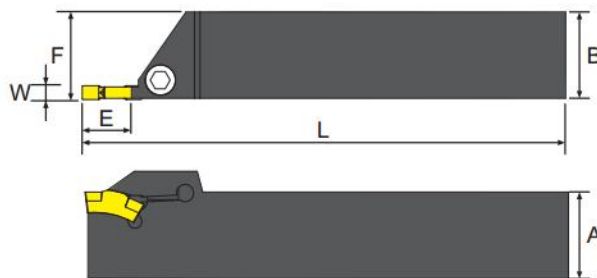

產品型號 Model No	在庫 Stock		寸法 Dimension(mm)						刀片 Insert	螺絲 Screw	L型扳手 Wrench	價格 Price
	R	L	A	B	E	F	L	W				
ETGDR/L-16-3M	●		16	16	16	16	125	3	TGMF	CS6-50	LW040	
ETGDR/L-20-3M	●		20	20	18	20	125	3				
ETGDR/L-20-4M	●		20	20	18	20	125	4-5				
ETGDR/L-25-3M	●		25	25	18	25	150	3				
ETGDR/L-25-4M	●		25	25	18	25	150	4-5				
ETGDR/L-25-5M	●		25	25	18	25	150	5-6.4				

●刀片：伊斯卡。

●Insert：Iscar.

EDGTR

新規格上市
New Specification Arrival

本圖所示為右手刀 (R)
Right Hand Show

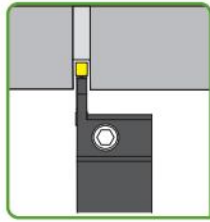

外徑切斷刀刀架系列

Tool Holders for External Deep Turning

- 可開槽、擴槽及外徑深加工等。
- 可切斷、修端面。
- Grooving, Broach grooving & deep grooving.
- Cut-off grooving & face grooving.

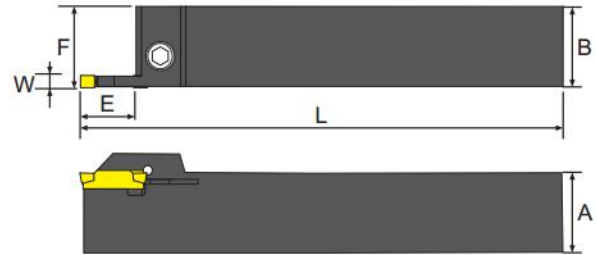

產品型號 Model No	在庫 Stock		寸法 Dimension(mm)						刀片 Insert	螺絲 Screw	L / 旗型扳手 Wrench	價格 Price
	R	L	A	B	E	F	L	W				
EDGTR/L-10B-2D-14	●		10	10	14	10	125	2	DGN	CS35-115	T15	
EDGTR/L-12B-2D-14	●	●	12	12	14	12	125	2				
EDGTR/L-10B-3D-14	●		10	10	14	10	125	3				
EDGTR/L-12B-3D-14	●	●	12	12	14	12	125	3				
EDGTR/L-16B-2D-14	●	●	16	16	14	16	125	2		CS6-50	LW040	
EDGTR/L-16B-3D-16	●	●	16	16	16	16	125	3				
EDGTR/L-20B-2D-14	●	●	20	20	14	20	125	2		CS6-60	LW050	
NEW EDGTR/L-20B-2D-16	●		20	20	16	20	125	2				
EDGTR/L-20B-3D-20	●	●	20	20	20	20	125	3				
EDGTR/L-25B-2D-14	●		25	25	14	25	150	2				
EDGTR/L-25B-3D-20	●	●	25	25	20	25	150	3				

●刀片：伊斯卡。

●Insert：Iscar.

EDGH

本圖所示為右手刀 (R)
Right Hand Show

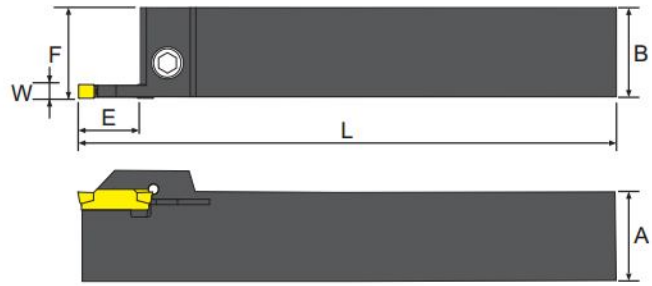
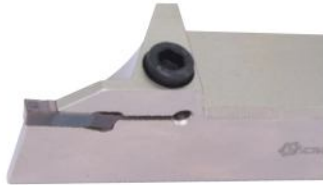
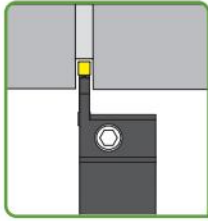

產品型號 Model No	在庫 Stock		寸法 Dimension(mm)					刀片 Insert	螺絲 Screw	L型扳手 Wrench	價格 Price	
	R	L	A	B	E	F	L					W
EDGHR-16B-3D-16			16	16	16	16	125	3	DGM	CS6-60	LW050	
EDGHR-16B-4D-16			16	16	16	16	125	4				
EDGHR/L-25B-3D-20			25	25	20	20	150	3				
EDGHR/L-20B-4D-20	●		20	20	20	20	125	4				
EDGHR/L-25B-4D-20			20	20	20	20	150	4				
EDGHR/L-25B-5D-25			25	25	25	25	150	5				

●刀片：三菱。 ●Insert：Mitsubishi.

EGYH

本圖所示為右手刀 (R)
Right Hand Show

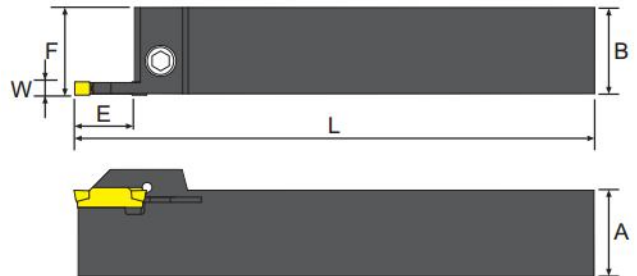
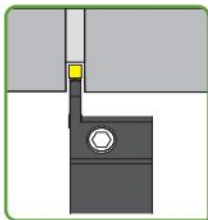

產品型號 Model No	在庫 Stock		寸法 Dimension(mm)					刀片 Insert	螺絲 Screw	L型扳手 Wrench	價格 Price	
	R	L	A	B	E	F	L					W
EGYHR/L-20K-2D-14	●	●	20	20	14	20	125	2	GY2M	CS6-60	LW050	
EGYHR/L-20K-2D-16	●	●	20	20	16	20	125	2				
EGYHR/L-20K-3D-20	●	●	20	20	20	20	125	3				
EGYHR/L-20K-4D-20	●	●	20	20	20	20	125	4				
EGYHR/L-25M-2D-16	●	●	25	25	16	25	150	2				
EGYHR/L-25M-3D-09	●	●	25	25	9	25	150	3				
EGYHR/L-25M-3D-20	●	●	25	25	20	25	150	3				
EGYHR/L-25M-4D-09	●	●	25	25	9	25	150	4				
EGYHR/L-25M-4D-20	●	●	25	25	20	25	150	4				
EGYHR/L-25M-5D-25	●	●	25	25	25	25	150	5				

●刀片：三菱。 ●Insert：Mitsubishi.

EGEHR 本圖所示為右手刀 (R)
Right Hand Show

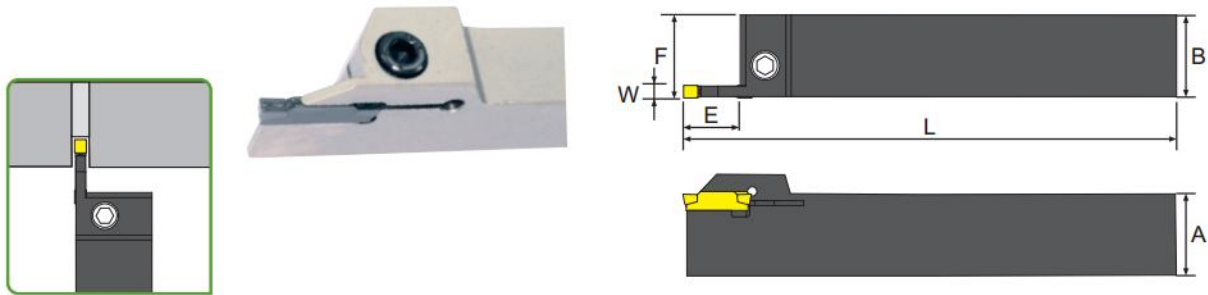

產品型號 Model No	在庫 Stock		寸法 Dimension(mm)						刀片 Insert	螺絲 Screw	L型板手 Wrench	價格 Price
	R	L	A	B	E	F	L	W				
EGEHR/L-16B-2D-14	●		16	16	14	16	125	2	MGMN	CS6-50	LW040	
EGEHR/L-16B-3D-14	●		16	16	14	16	125	3				
EGEHR/L-20B-2D-14	●		20	20	14	20	125	2				
EGEHR/L-20B-3D-20	●	●	20	20	20	20	125	3		CS6-60	LW050	
EGEHR/L-20B-4D-20	●	●	20	20	20	20	125	4				
EGEHR/L-25B-2D-14	●	●	25	25	14	25	150	2				
EGEHR/L-25B-3D-20	●	●	25	25	20	25	150	3				
EGEHR/L-25B-4D-20	●	●	25	25	20	25	150	4				
EGEHR/L-25B-5D-25	●	●	25	25	25	25	150	5				

- 刀片：克洛伊。
- Insert：Korloy