



L

機床配件 Machine Accessories

搪孔刀	Boring Tool	BJ	L02
內孔刀具定位座	Lathe Quick Center Block	ETHR	L02
中心鑽刀桿	Centre-Drill Holder	ECH	L03
套筒	Sleeve	SHB	L04
		EHR	L05
		EHR-O	L07
		EHRMT	L08
E R 夾頭柄	ER Collet Chuck	EKA	L09
E C-E R 筒夾螺母	EC-ER Collet Nut	EC-ER	L09
E R 扳手	ER Wrench	NEW ER	L10
E R 筒夾	ER Collet	ER	L10

BJ

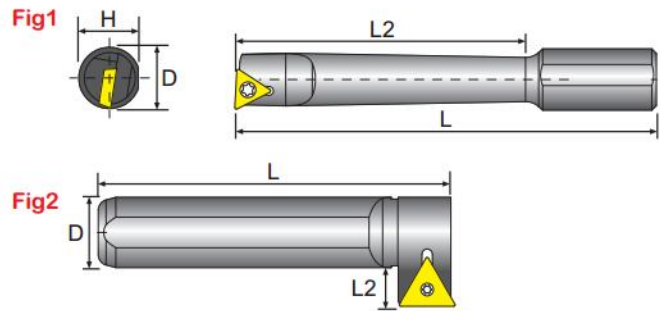

產品型號 Model No	在庫 Stock	寸法 Dimension(mm)				加工範圍 Range	圖解 Fig	刀片 Insert	螺絲 Screw	旗型扳手 Wrench	價格 Price
		D	H	L	L2						
BJ2008-32	●	20	18	80	32	8-10	1	TB□□0601□□	CS20	T-6	
BJ2010-40	●	20	18	87	40	10-12	1				
BJ2012-53	●	20	18	98	53	12-16	1	TP□□0902□□	CS25	T-8	
BJ2016-68	●	20	18	110	68	16-20	1				
BJ2020-83	●	20	18	122	83	20-25	1	TP□□1103□□	CS30	T-10	
BJ2025-96	●	20	18	133	96	25-30	1				
BJ2030-115	●	20	18	152	115	30-35	1				
BJ-L20-36		20	18	100	8	—	2				

●刀片資料：TB□□0601□□→參考A40頁，TP□□0902□□、TP□□1103□□→參考A29頁
●Insert Detail：TB□□0601□□→Ref.Page-A40，TP□□0902□□、TP□□1103□□→Ref.Page-A29

ETHR

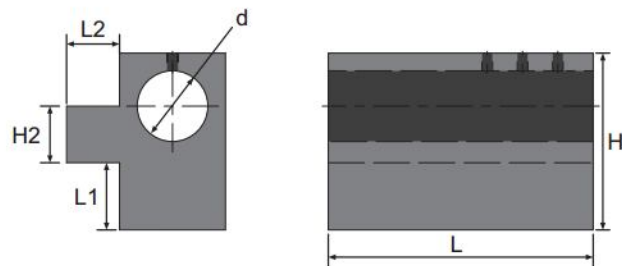

產品型號 Model No	在庫 Stock	寸法 Dimension(mm)						無頭螺絲 Screw	L型扳手 Wrench	價格 Price
		d	H	H2	L	L1	L2			
ETHR2032	●	32	64	20	80	18	23	ES-808	LW040	
ETHR2532	●	32	64	25	80	18	23			
ETHR2040	●	40	76	20	90	30	35	ES-810	LW040	
ETHR2540	●	40	76	25	90	30	35			
ETHR3240	●	40	76	32	90	30	35			

ECH 材質：鋼
Shank：Steel

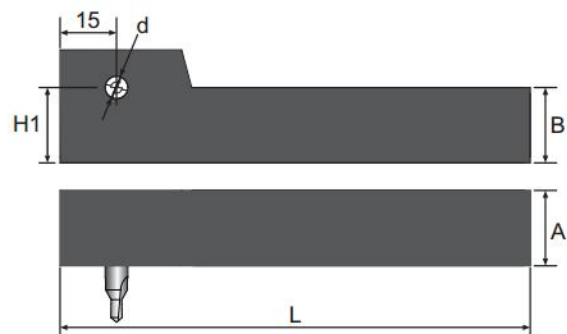

寸法 Dimension(mm)

產品型號 Model No	在庫 Stock	寸法 Dimension(mm)					圖解 Fig	無頭螺絲 Screw	L型扳手 Wrench	價格 Price
		d	A	B	H1	L				
ECH-2020K05	●	5	20	20	20	125	1	ES-410	LW020	
ECH-2020K06	●	6	20	20	20	125	1	ES-510	LW025	
ECH-2020K08	●	8	20	20	20	125	1	ES-610	LW030	
ECH-2020K10	●	10	20	20	20	125	1	ES-810	LW040	
ECH-2020K12	●	12	20	20	20	125	1			
ECH-2525M05	●	5	25	25	25	150	2	ES-410	LW020	
ECH-2525M06	●	6	25	25	25	150	2	ES-510	LW025	
ECH-2525M08	●	8	25	25	25	150	1	ES-610	LW030	
ECH-2525M10	●	10	25	25	25	150	1	ES-810	LW040	
ECH-2525M12	●	12	25	25	25	150	1			

SHB 材質：鋼
Shank：Steel

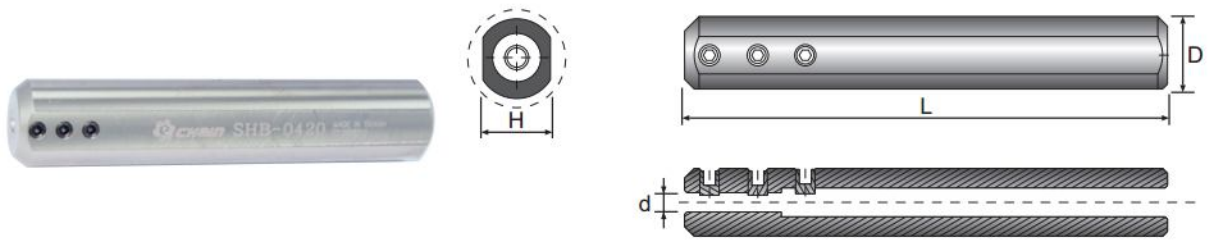

產品型號 Model No	在庫 Stock	寸法 Dimension(mm)				適用刀具 Assembly Holder	無頭螺絲 Screw	L型扳手 Wrench	價格 Price
		d	D	H	L				
SHB-0316	●	3	16	15	100		ES-306	LW015	
SHB-0416	●	4	16	15	100	C04	ES-404	LW020	
SHB-0516	●	5	16	15	100	C05			
SHB-0616	●	6	16	15	100	C06			
SHB-0816	●	8	16	15	100	C08/S08	ES-606	LW030	
SHB-1016	●	10	16	15	100	C10/S10			
SHB-04-19.05	●	4	19.05	18.05	100	C04	ES-406	LW020	
SHB-05-19.05	●	5	19.05	18.05	100	C05			
SHB-06-19.05	●	6	19.05	18.05	100	C06			
SHB-08-19.05	●	8	19.05	18.05	100	C08	ES-606	LW030	
SHB-10-19.05	●	10	19.05	18.05	100	C10			
SHB-12-19.05	●	12	19.05	18.05	100	C12			
SHB-0420	●	4	20	19	100	C04	ES-404	LW020	
SHB-0520	●	5	20	19	100	C05	ES-406		
SHB-0620	●	6	20	19	100	C06			
SHB-0820	●	8	20	19	100	C08	ES-606	LW030	
SHB-1020	●	10	20	19	100	C10			
SHB-1220	●	12	20	19	100	C12			
SHB-0422	●	4	22	21	100	C04	ES-406	LW020	
SHB-0522	●	5	22	21	100	C05	ES-404		
SHB-0622	●	6	22	21	100	C06	ES-406		
SHB-0822	●	8	22	21	100	C08/S08	ES-606	LW030	
SHB-1022	●	10	22	21	100	C10/S10			
SHB-1222	●	12	22	21	100	C12/S12			
SHB-1622	●	16	22	21	100	C16/S16			

●刀架需另購→參考H18、H51、H52頁
●Holder Refer Page-H18、H51、H52

EHR
新規格上市
New Specification Arrival

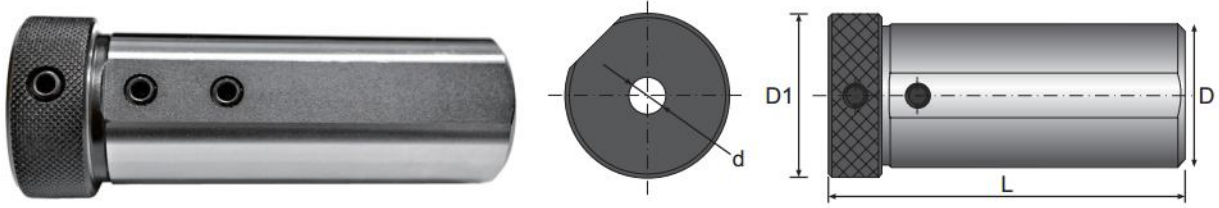
 材質：鋼
Shank : Steel

圖示 Fig	產品型號 Model No	在庫 Stock	寸法 Dimension(mm)				無頭螺絲 Screw	價格 Price
			d	D	D1	L		
	EHR-0625	●	6	25	34	64	ES-606	
	EHR-0825	●	8	25	34	64		
	EHR-1025	●	10	25	34	64		
	EHR-1225	●	12	25	34	64		
	EHR-1625	●	16	25	34	64	-	
	EHR-2025	●	20	25	34	64		
	EHR-06-25.4	●	6	25.4	34	64	ES-606	
	EHR-08-25.4	●	8	25.4	34	64		
	EHR-10-25.4	●	10	25.4	34	64		
	EHR-12-25.4	●	12	25.4	34	64		
	EHR-16-25.4	●	16	25.4	34	64	-	
	EHR-0632	●	6	32	38	100	ES-610	
	EHR-0832	●	8	32	38	100		
	EHR-1032	●	10	32	38	100	ES-810	
	EHR-1232	●	12	32	38	100		
	EHR-1632	●	16	32	38	100	ES-806	
	EHR-2032	●	20	32	38	100	ES-810	
	EHR-2532	●	25	32	38	100	ES-806	

※ 請接下頁。 ※ Continued on next page.

圖示 Fig	產品型號 Model No	在庫 Stock	寸法 Dimension(mm)				無頭螺絲 Screw	價格 Price
			d	D	D1	L		
	EHR-0640	●	6	40	46	100	ES-610	
	EHR-0840	●	8	40	46	100		
	EHR-1040	●	10	40	46	100	ES-810	
	EHR-1240	●	12	40	46	100		
	EHR-1440	●	14	40	46	100		
	EHR-1640	●	16	40	46	100		
	NEW EHR-2040A	●	20	40	46	100		
	EHR-2040	●	20	40	46	100	ES-806	
	EHR-2540	●	25	40	46	100		
	EHR-3240	●	32	40	46	100		
	EHR-0650	●	6	50	58	100	ES-610	
	EHR-0850	●	8	50	58	100		
	EHR-1050	●	10	50	58	100	ES-810	
	EHR-1250	●	12	50	58	100		
	EHR-1650	●	16	50	58	100		
	EHR-2050	●	20	50	58	100		
	EHR-2550	●	25	50	58	100	ES-808	
	EHR-3250	●	32	50	58	100		
	EHR-4050	●	40	50	58	100		

●刀架需另購→參考H18、H51、H52頁
●Holder Refer Page-H18、H51、H52

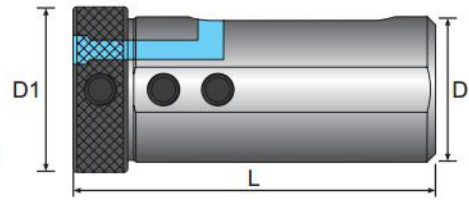
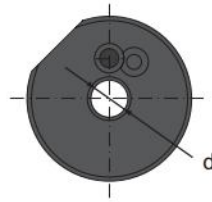
EHR-O 材質：鋼
 Shank : Steel

圖示 Fig	產品型號 Model No	在庫 Stock	寸法 Dimension(mm)				無頭螺絲 Screw	可調出水孔	螺絲 Screw	價格 Price
			d	D	D1	L				
	EHR-0632-O	●	6	32	38	100	ES-610	EHR-O	TS408	
	EHR-0832-O	●	8	32	38	100				
	EHR-1032-O	●	10	32	38	100	ES-810			
	EHR-1232-O	●	12	32	38	100				
	EHR-1632-O	●	16	32	38	100				ES-806
	EHR-0640-O	●	6	40	46	100	ES-610			
	EHR-0840-O	●	8	40	46	100				
	EHR-1040-O	●	10	40	46	100	ES-810			
	EHR-1240-O	●	12	40	46	100				
	EHR-1640-O	●	16	40	46	100				
	EHR-2040-O	●	20	40	46	100				

- 刀架需另購→參考H18、H51、H52頁
- Holder Refer Page-H18、H51、H52

EHRMT 材質：鋼
Shank：Steel

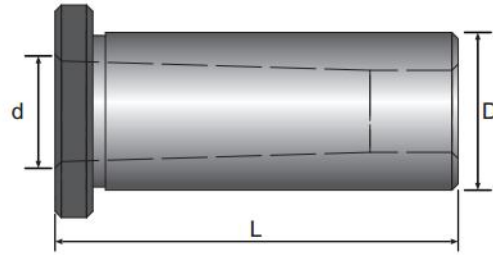

寸法 Dimension(mm)

產品型號 Model No	在庫 Stock	D	d	L	價格 Price
EHRMT1-25	●	25	MT1	70	
EHRMT2-25	●	25	MT2	80	
EHRMT3-25	●	25	MT3	90	
EHRMT1-32	●	32	MT1	85	
EHRMT2-32	●	32	MT2	85	
EHRMT3-32	●	32	MT3	100	
EHRMT1-40	●	40	MT1	87	
EHRMT2-40	●	40	MT2	87	
EHRMT3-40	●	40	MT3	87	
EHRMT4-40	●	40	MT4	116	
EHRMT1-50	●	50	MT1	120	
EHRMT2-50	●	50	MT2	120	
EHRMT3-50	●	50	MT3	120	
EHRMT4-50	●	50	MT4	120	

- 刀架需另購→參考H18、H51、H52頁
- Holder Refer Page-H18、H51、H52

EKA  新規格上市
材質：鋼
Shank：Steel

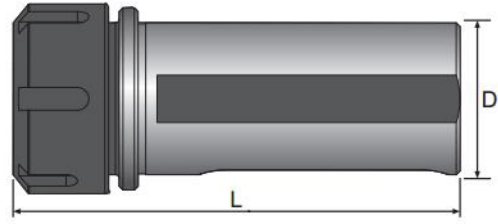

產品型號 Model No	在庫 Stock	夾持範圍 Capacity	寸法 Dimension(mm)		無頭螺絲 Screw	無頭螺絲 Screw	價格 Price
			D	L			
NEW EKA-ER16-C25-95	●	0.5-10	25	95	ES-806	ES1225	
NEW EKA-ER20-C25-95	●	2-13	25	95			
EKA-ER20-C32-120	●	2-13	32	120			
EKA-ER20-C40-120	●	2-13	40	120	ES-810		
EKA-ER25-C32-120	●	2-16	32	120	ES-806		
EKA-ER25-C40-120	●	2-16	40	120	ES-810		
EKA-ER32-C40-120	●	3-20	40	120			

●刀架需另購→參考H18、H51、H52頁
●Holder Refer Page-H18、H51、H52

EC-ER

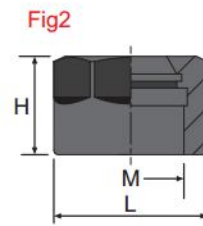
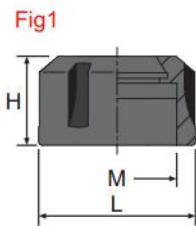

寸法 Dimension(mm)

產品型號 Model No	在庫 Stock	圖解 Fig	D	H	M	價格 Price
EC-ER16	●	2	28	18.7	22	
EC-ER20	●	2	34	21.7	25	
EC-ER25	●	1	42	23.8	32	
EC-ER32	●	1	50	25.2	40	

ER **新品上市**
New Arrival

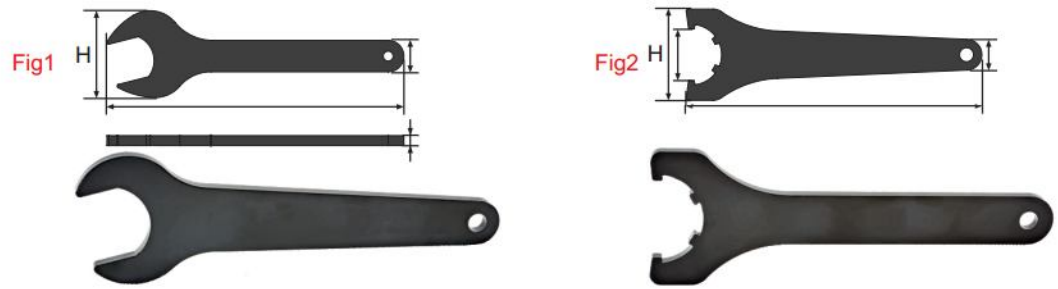

寸法 Dimension(mm)

產品型號 Model No	在庫 Stock	圖解 Fig	D	H	M	價格 Price
NEW ER-16A	●	1	28	18.7	22	
NEW ER-20A	●	1	34	21.7	25	
NEW ER-25A	●	2	42	23.8	32	
NEW ER-32A	●	2	50	25.2	40	

ER

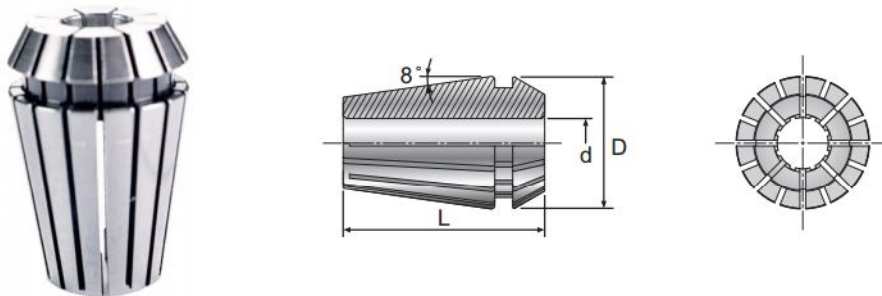

寸法 Dimension(mm)

產品型號 Model No	在庫 Stock	d	D	L	價格 Price
ER11-	●	2、3、4、5、6	11.5	18	
ER16-	●	2、3、4、5、6、8、9、10	17	27	
ER20-	●	2、3、3.5、4、4.5、5、5.5、6、6.5、7、7.5、8、8.5、9、9.5、10、10.5、11、11.5、12、12.5、13	21	31	
ER25-	●	2、3、4、5、6、7、8、9、10、11、12、12.5、13、14、15、16	26	34	
ER32-	●	3、4、6、8、9、10、10.5、11、11.5、12、13、14、15、16、17、18、19、20	33	40	
ER40-	●	4、13、16、20、23、26	41	46	