















# G

## 微小徑內徑車刀 Tiny Carbide Boring Bar

微小徑內徑鎢鋼車刀識別系統 Tiny Carbide Boring Bar Identification System ..... G03

微小徑內徑鎢鋼車刀索引表 Tiny Carbide Boring Bar Series Index ..... G04

-  GP\_R ..... G05
-  GQ\_R ..... G06
-  GT\_R ..... G07—G08
-  GU\_R ..... G09
-  GX\_R ..... G09
-  GW\_R ..... G10
-  GV\_R ..... G10
-  GG\_R ..... G11
-  GK\_R ..... G12
-  GF\_R ..... G13
-  GF\_L ..... G14
-  GD\_R ..... G15
-  GZ\_R ..... G16

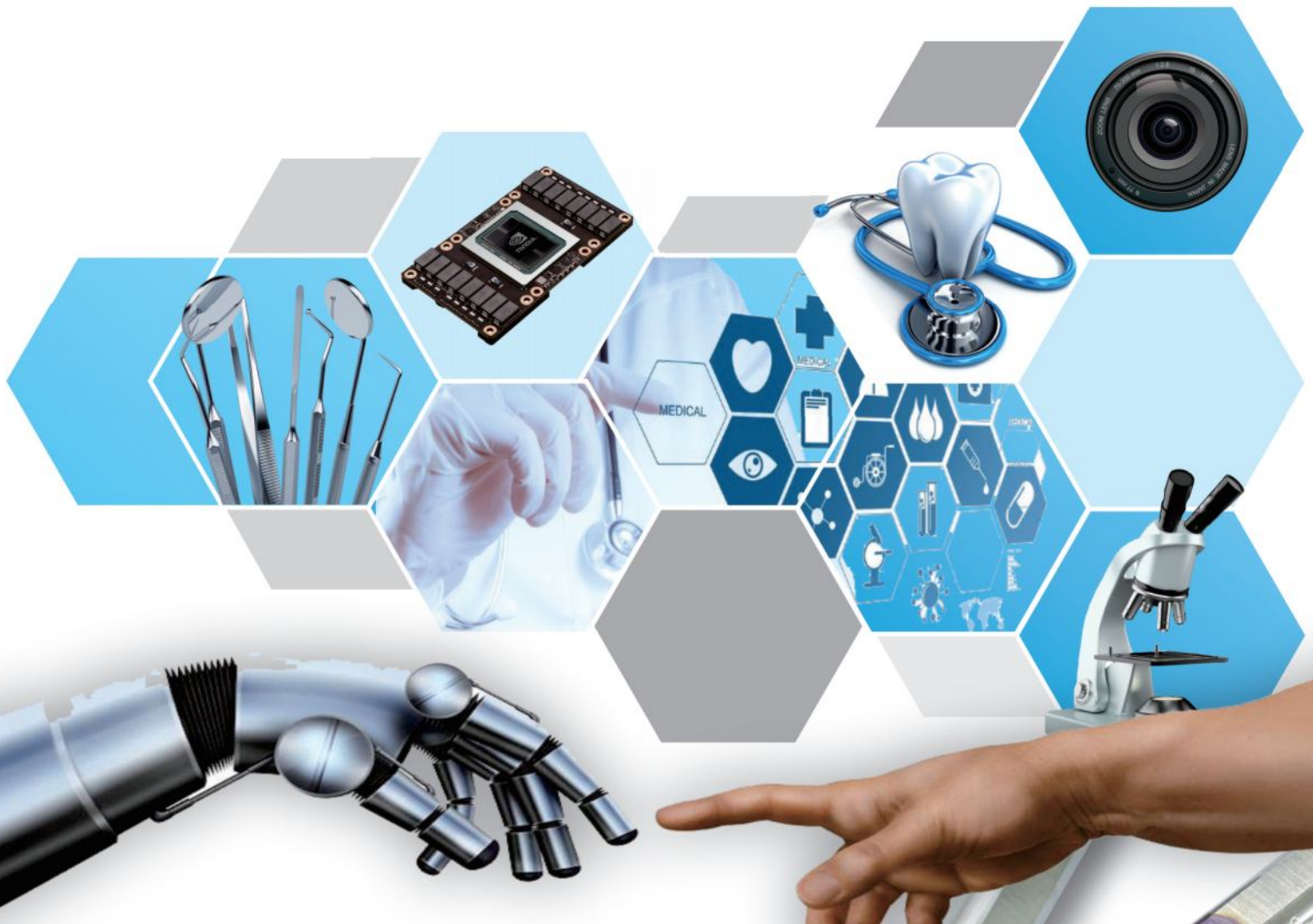

## 微小徑內徑車刀 Tiny Carbide Boring Bar

適用於專業醫療設備、電子、化學及工業等精密細小零件之製造加工

Apply on manufacturing and processing of precision small parts such as professional medical equipment, electronics, chemicals and industry.

- 微小徑內徑鎢鋼車刀採用全鎢鋼刀體，有效抑制加工震動  
 Tiny carbide boring bar adopts a full carbide cutter body to effectively suppress the processing vibration.
- 採用超細粒子硬質合金AlTiN塗層，增加刀具耐磨耗性  
 Ultra-fine particle cemented carbide AlTiN coating for increased tool wearability.

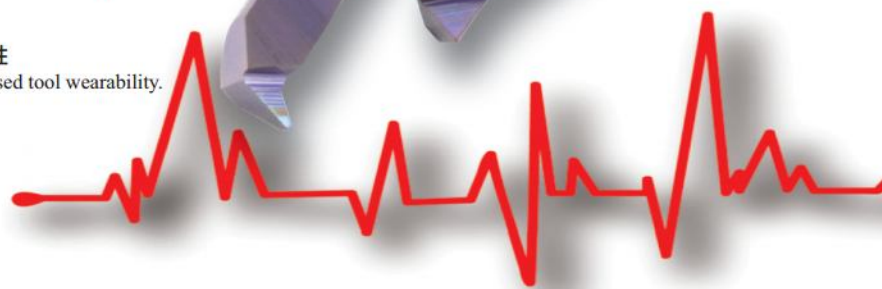

- 微小徑設計有利於狹小孔徑空間工件之切槽、仿形及倒角等加工需求  
 The micro-diameter design is beneficial to the processing requirements of cutting, copying and chamfering of workpieces in narrow apertures.
- 提供精確的加工精準度和良好表面光潔度  
 Provides precise machining accuracy and good surface finish.

搭配 **SHB** 專用套筒  
 With SHB Series Dedicated Sleeve

達到精確快速定位  
 for precise and fast positioning



# 微小徑內徑鎢鋼車刀識別系統

Tiny Carbide Boring Bar Identification System

# G W □ R L □ □ R □ □ A □ □

1
2
3
4
5
6
7

- 1 塗層  
Coating
- 2 特徵  
Feature
- 3 柄徑  
Shank Diameter
- 4 加工方向  
Hand Of Tool
- 5 頸部長度  
Long Flute Neck

## 1 塗層 Coating

記號 Sign	塗層 Coating	記號 Sign	塗層 Coating
G	G300	M	M500

## 6 刀尖R角&刀寬尺寸 Comer Radius & Insert Width

## 7 其他 Other

## 2 特徵 Feature

記號 Sign	特徵 Feature
C	倒角 Chamfering
D	內螺紋倒角 Thread Relief
F	平面銑削 Facing
G	開槽切削 Grooving
I	內螺紋 Threading
K	內徑圓鼻開槽 Full Radius Grooving
P	仿型車削 Profiling
Q	仿型&搪孔 Profiling & Boring
T	車削 Turning
U	90° 仿型 90° Profiling
V	深面切斷刀 Deep Face Grooving
W	倒角&仿型 Chamfering & Profiling
X	後掃車削 Back Turning
Z	端面圓槽 Full Radius Facing

## 3 柄徑 Shank Diameter

記號 Sign	柄徑 Shank Diameter
3	3 mm
4	4 mm
5	5 mm
6	6 mm
8	8 mm
10	10 mm

## 4 加工方向 Hand Of Tool

記號 Sign	方向 Direction
R	右手刀 Right Hand
L	左手刀 Left Hand

## 5 頸部長度 Neck Length

記號 Sign	長度 Eextent	記號 Sign	長度 Eextent
L104	4 mm	L122	22 mm
L105	5 mm	L124	24 mm
L106	6 mm	L127	27 mm
L110	10 mm	L130	30 mm
L115	15 mm	L135	35 mm
L118	18 mm	L143	43 mm

## 6 刀尖R角&刀寬尺寸

Comer Radius &amp; Insert Width





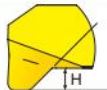

















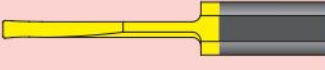

記號 Sign	刀尖R角&刀寬尺寸 Comer Radius & Insert Width	記號 Sign	刀尖R角&刀寬尺寸 Comer Radius & Ins
R	R0.05=Nose Radius 0.05 mm	B	B1.0=0.1mm
	R0.1=Nose Radius 0.1 mm		B1.5=1.5mm
	R2=Nose Radius 2 mm		B2.0=2.0mm

## 7 其他 Other

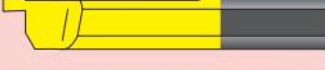
A□□	A60=角度Angle 60° A90=角度Angle 90°	E		H	
-----	------------------------------------	---	---	---	---

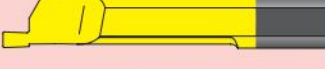
# 微小徑內徑鎢鋼車刀索引表

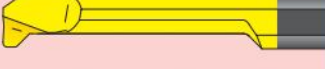
## Tiny Carbide Boring Bar Series Index

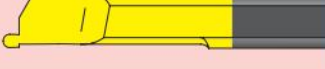
產品 Product	柄徑 (D) Shank Dia.(mm)	加工徑 Min Bore Dia	塗層 Coating	頁碼 Page
 GP_R 	Ø3 Ø6 Ø4 Ø8 Ø5 Ø10	1~10.1	MG	G05
 GQ_R 	Ø4 Ø8 Ø5 Ø6	4.1~8.1	MG	G06
 GT_R 	Ø3 Ø6 Ø4 Ø8 Ø5 Ø10	1~10.1	MG	G07-G08
 GU_R 	Ø3 Ø6 Ø4 Ø8 Ø5	3.1~8.1	MG	G09
 GX_R 	Ø4 Ø5 Ø6	3.1~6.1	MG	G09
 GW_R 	Ø6	1	MG	G10
 GV_R 	Ø6 Ø8	12~20	MG	G10
 GG_R 	Ø3 Ø6 Ø4 Ø8 Ø5	3.1~8.1	MG	G11
 GK_R 	Ø4 Ø5 Ø6	4.1~6.1	MG	G12
 GF_L 	Ø4 Ø8 Ø5 Ø6	5~10	MG	G13
 GF_R 	Ø4 Ø8 Ø5 Ø6	5~10	MG	G14
 GD_R 	Ø4 Ø5 Ø6	4.1~6.1	MG	G15
 GZ_R 	Ø4 Ø5 Ø6	5~8	MG	G16

**GP\_R**

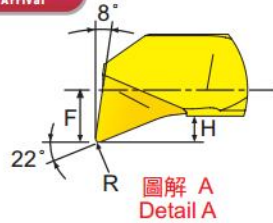
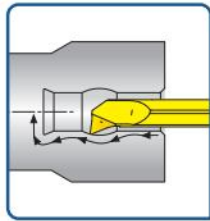
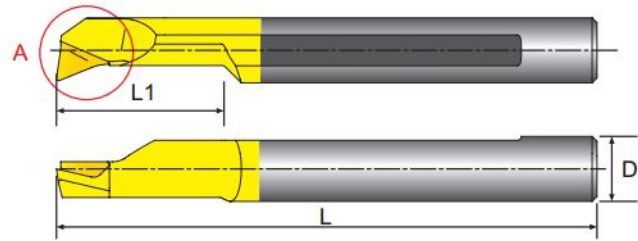
**新品上市**  
 New Arrival

 圖解 A  
 Detail A

寸法 Dimension(mm)

產品型號 Model No	在庫 Stock	加工徑 Min Bore Dia	R	F	H	D	L	L1	價格 Price
<b>NEW</b> GP1RL104R005		1	0.05	0.5	0.2	3	39	4	
<b>NEW</b> GP1.5RL106R01		1.5	0.1	0.7	0.3	3	39	6	
<b>NEW</b> GP2RL110R005		2.1	0.05	0.8	0.5	3	39	10	
<b>NEW</b> GP2RL110R01		2.1	0.1	0.8	0.5	3	39	10	
<b>NEW</b> GP2RL105R015		2.1	0.15	0.8	0.5	3	39	5	
<b>NEW</b> GP2RL110R015		2.1	0.15	0.8	0.5	3	39	10	
<b>NEW</b> GP3RL110R005		3.1	0.05	1.3	0.7	3	39	10	
<b>NEW</b> GP3RL115R005		3.1	0.05	1.3	0.7	3	39	15	
<b>NEW</b> GP3RL115R01		3.1	0.1	1.3	0.7	3	39	15	
<b>NEW</b> GP3RL122R01		3.1	0.1	1.3	0.7	3	50	22	
<b>NEW</b> GP3RL110R02		3.1	0.2	1.3	0.7	3	39	10	
<b>NEW</b> GP3RL115R02		3.1	0.2	1.3	0.7	3	39	15	
<b>NEW</b> GP3RL122R02		3.1	0.2	1.3	0.7	3	50	22	
<b>NEW</b> GP4RL115R01		4.1	0.1	1.7	0.8	4	50	15	
<b>NEW</b> GP4RL122R01		4.1	0.1	1.7	0.8	4	50	22	
<b>NEW</b> GP4RL110R02		4.1	0.2	1.7	0.8	4	50	10	
<b>NEW</b> GP4RL115R02		4.1	0.2	1.7	0.8	4	50	15	
<b>NEW</b> GP4RL122R02		4.1	0.2	1.7	0.8	4	50	22	
<b>NEW</b> GP5RL122R01		5.1	0.1	2.1	1.2	5	50	22	
<b>NEW</b> GP5RL130R01		5.1	0.1	2.1	1.2	5	75	30	
<b>NEW</b> GP5RL115R02		5.1	0.2	2.1	1.2	5	50	15	
<b>NEW</b> GP5RL122R02		5.1	0.2	2.1	1.2	5	50	22	
<b>NEW</b> GP5RL130R02		5.1	0.2	2.1	1.2	5	75	30	
<b>NEW</b> GP6RL115R02		6.1	0.2	2.8	1.4	6	50	15	
<b>NEW</b> GP6RL122R02	●	6.1	0.2	2.8	1.4	6	50	22	
<b>NEW</b> GP6RL130R02		6.1	0.2	2.8	1.4	6	75	30	
<b>NEW</b> GP8RL115R02		8.1	0.2	3.8	1.6	8	60	15	
<b>NEW</b> GP8RL122R02		8.1	0.2	3.8	1.6	8	60	22	
<b>NEW</b> GP8RL135R02		8.1	0.2	3.8	1.6	8	75	35	
<b>NEW</b> GP10RL135R02		10.1	0.2	4.8	2	10	75	35	

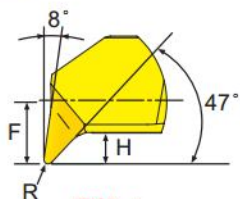
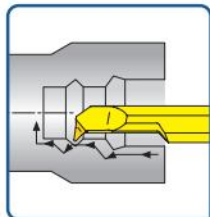
I GQ\_R  新品上市  
 New Arrival



圖解 A  
 Detail A

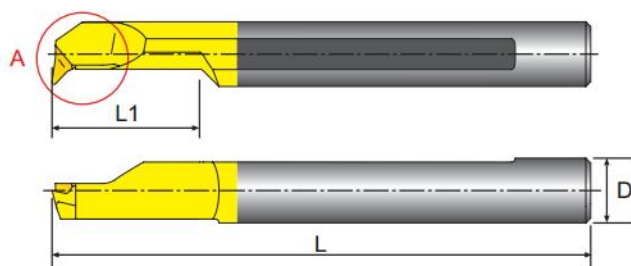

寸法 Dimension(mm)

產品型號 Model No	在庫 Stock	加工徑 Min Bore Dia	R	F	H	D	L	L1	價格 Price
<b>NEW</b> GQ4RL110R02		4.1	0.2	1.8	0.8	4	50	10	
<b>NEW</b> GQ4RL115R02		4.1	0.2	1.8	0.8	4	50	15	
<b>NEW</b> GQ4RL122R02		4.1	0.2	1.8	0.8	4	50	22	
<b>NEW</b> GQ5RL115R02		5.1	0.2	2.3	1	5	50	15	
<b>NEW</b> GQ5RL122R02		5.1	0.2	2.3	1	5	50	22	
<b>NEW</b> GQ6RL115R02	●	6.1	0.2	2.8	1.4	6	50	15	
<b>NEW</b> GQ6RL122R02		6.1	0.2	2.8	1.4	6	50	22	
<b>NEW</b> GQ6RL130R02		6.1	0.2	2.8	1.4	6	60	30	
<b>NEW</b> GQ8RL122R02		8.1	0.2	3.8	1.6	8	60	22	
<b>NEW</b> GQ8RL127R02		8.1	0.2	3.8	2	8	60	27	

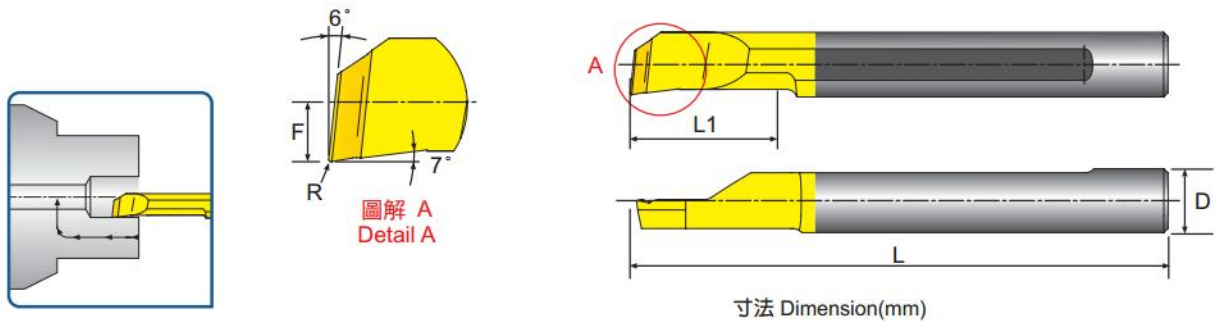
**GT\_R**  **新品上市**  
 New Arrival

寸法 Dimension(mm)

產品型號 Model No	在庫 Stock	加工徑 Min Bore Dia	R	F	D	L	L1	價格 Price
<b>NEW</b> GT1RL104R005	●	1	0.05	0.5	3	39	4	
<b>NEW</b> GT1.5RL106R01	●	1.5	0.1	0.7	3	39	6	
<b>NEW</b> GT2RL110R005	●	2.1	0.05	0.8	3	39	10	
<b>NEW</b> GT2RL105R015	●	2.1	0.15	0.8	3	39	5	
<b>NEW</b> GT2RL110R015	●	2.1	0.15	0.8	3	39	10	
<b>NEW</b> GT3RL110R005	●	3.1	0.05	1.3	3	39	10	
<b>NEW</b> GT3RL115R005	●	3.1	0.05	1.3	3	39	15	
<b>NEW</b> GT3RL115R01	●	3.1	0.1	1.3	3	39	15	
<b>NEW</b> GT3RL110R02	●	3.1	0.2	1.3	3	39	10	
<b>NEW</b> GT3RL115R02	●	3.1	0.05	1.3	3	39	15	
<b>NEW</b> GT4RL115R005		4.1	0.05	1.7	4	50	15	
<b>NEW</b> GT4RL110R01		4.1	0.1	1.7	4	50	10	
<b>NEW</b> GT4RL115R01		4.1	0.1	1.7	4	50	15	
<b>NEW</b> GT4RL122R01		4.1	0.1	1.7	4	50	22	
<b>NEW</b> GT4RL110R02		4.1	0.2	1.7	4	50	10	
<b>NEW</b> GT4RL115R02		4.1	0.2	1.7	4	50	15	
<b>NEW</b> GT4RL122R02		4.1	0.2	1.7	4	50	22	
<b>NEW</b> GT5RL115R005		5.1	0.05	2.1	5	50	15	
<b>NEW</b> GT5RL115R01		5.1	0.1	2.1	5	50	15	
<b>NEW</b> GT5RL122R01		5.1	0.1	2.1	5	50	22	
<b>NEW</b> GT5RL130R01		5.1	0.1	2.1	5	75	30	
<b>NEW</b> GT5RL115R02		5.1	0.2	2.1	5	50	15	
<b>NEW</b> GT5RL122R02		5.1	0.2	2.1	5	50	22	
<b>NEW</b> GT5RL130R02		5.1	0.2	2.1	5	75	30	
<b>NEW</b> GT6RL115R005		6.1	0.05	2.8	6	50	15	
<b>NEW</b> GT6RL115R01		6.1	0.1	2.8	6	50	15	
<b>NEW</b> GT6RL115R02		6.1	0.2	2.8	6	50	15	
<b>NEW</b> GT6RL122R02		6.1	0.2	2.8	6	50	22	

※ 請接下頁。 ※ Continued on next page.

寸法 Dimension(mm)

產品型號 Model No	在庫 Stock	加工徑 Min Bore Dia	R	F	D	L	L1	價格 Price
 GT6RL130R02		6.1	0.2	2.8	6	60	30	
 GT6RL135R02		6.1	0.2	2.8	6	75	35	
 GT8RL115R02		8.1	0.2	3.8	8	60	15	
 GT8RL122R02		8.1	0.2	3.8	8	60	22	
 GT8RL135R02		8.1	0.2	3.8	8	75	35	
 GT10RL135R02		10.1	0.2	4.8	10	75	35	



**GU\_R**  **新品上市**  
New Arrival

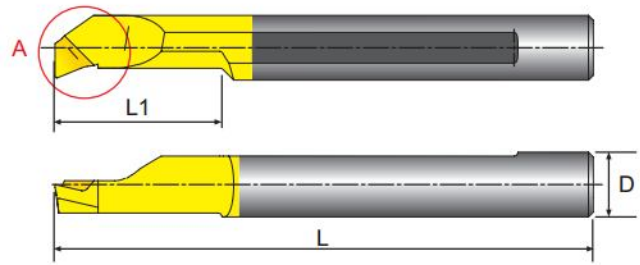
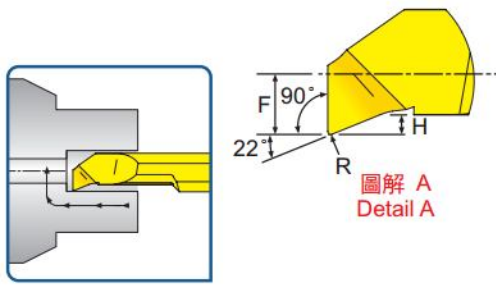

寸法 Dimension(mm)

產品型號 Model No	在庫 Stock	加工徑 Min Bore Dia	R	F	H	D	L	L1	價格 Price
<b>NEW</b> GU3RL110R005		3.1	0.05	1.3	0.4	3	39	10	
<b>NEW</b> GU3RL115R005		3.1	0.05	1.3	0.4	3	39	15	
<b>NEW</b> GU4RL110R01		4.1	0.1	1.7	0.5	4	50	10	
<b>NEW</b> GU4RL115R01		4.1	0.1	1.7	0.5	4	50	15	
<b>NEW</b> GU5RL115R015		5.1	0.15	2.1	0.7	5	50	15	
<b>NEW</b> GU5RL122R015		5.1	0.15	2.1	0.7	5	50	22	
<b>NEW</b> GU6RL115R015		6.1	0.15	2.8	0.9	6	50	15	
<b>NEW</b> GU6RL122R015		6.1	0.15	2.8	0.9	6	50	22	
<b>NEW</b> GU8RL122R02		8.1	0.2	3.8	1	8	60	22	

**GX\_R** 微小徑內徑後掃車削鎢鋼車刀柄  
Tiny Bank Tuming Carbide Boring Bar

 **新品上市**  
New Arrival

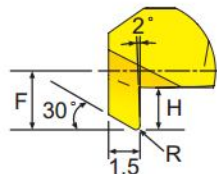
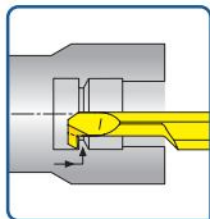

圖解 A  
Detail A

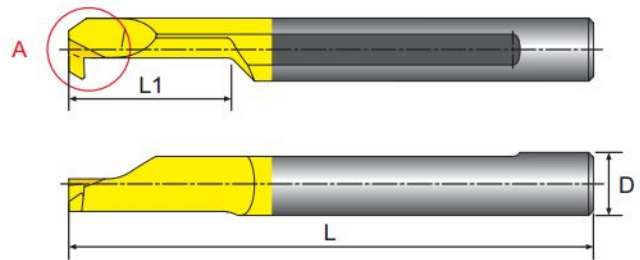

寸法 Dimension(mm)

產品型號 Model No	在庫 Stock	加工徑 Min Bore Dia	R	F	H	D	L	L1	價格 Price
<b>NEW</b> GX4RL110R01		3.1	0.1	1.3	0.5	4	50	10	
<b>NEW</b> GX4RL110R015		4.1	0.15	1.6	0.8	4	50	10	
<b>NEW</b> GX4RL115R015		4.1	0.15	1.6	0.8	4	50	15	
<b>NEW</b> GX5RL115R02		5.1	0.2	2.2	1	5	50	15	
<b>NEW</b> GX5RL122R02		5.1	0.2	2.2	1	5	50	22	
<b>NEW</b> GX6RL115R02		6.1	0.2	2.8	1.8	6	50	15	
<b>NEW</b> GX6RL122R02		6.1	0.2	2.8	1.8	6	50	22	

**GW\_R**  **新品上市**  
New Arrival

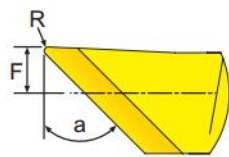
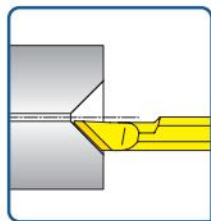

圖解 A  
Detail A

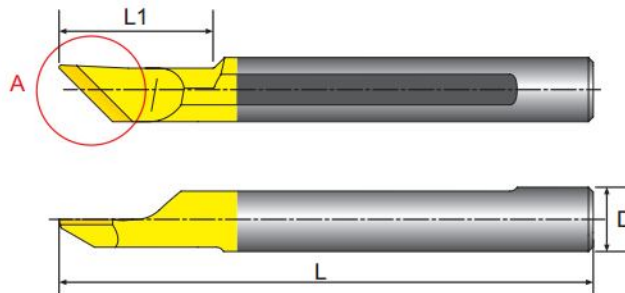

寸法 Dimension(mm)

產品型號 Model No	在庫 Stock	加工徑 Min Bore Dia	R	F	$\alpha$	$\beta$	D	L	L1	價格 Price
<b>NEW</b> GW6RL115R02A90		1	0.2	2.3	45°	45°	6	50	15	
<b>NEW</b> GW6RL115R02A60		1	0.2	2.3	60°	30°	6	50	15	

**GV\_R** 極小徑內徑深面切斷鎢鋼車刀柄  
Tiny Deep Face Grooving Carbide Boring Bar

 **新品上市**  
New Arrival

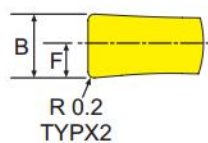
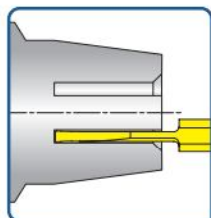

圖解 A  
Detail A

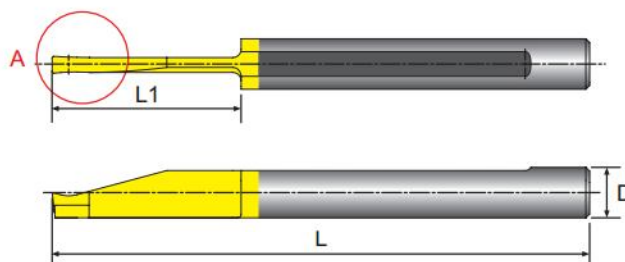

寸法 Dimension(mm)

產品型號 Model No	在庫 Stock	加工徑 Min Bore Dia	B	F	D	L	L1	價格 Price
<b>NEW</b> GV6RL115B20		12	2	1.1	6	60	15	
<b>NEW</b> GV6RL122B20		12	2	1.1	6	60	22	
<b>NEW</b> GV6RL122B25		12	2.5	1.4	6	60	22	
<b>NEW</b> GV8RL127B30		15	3	1.6	8	60	27	
<b>NEW</b> GV8RL143B30		15	3	1.6	8	75	43	
<b>NEW</b> GV8RL143B40		20	4	2.1	8	75	43	

GG\_R  新品上市  
New Arrival

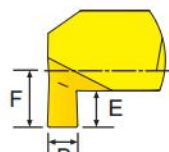
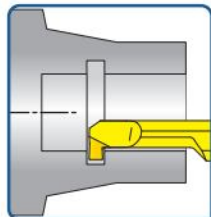

圖解 A  
Detail A

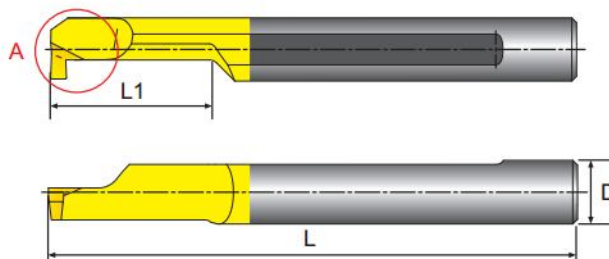

寸法 Dimension(mm)

產品型號 Model No	在庫 Stock	加工徑 Min Bore Dia	B	F	E	D	L	L1	價格 Price
<b>NEW</b> GG3RL110B07		3.1	0.7	1.3	0.6	3	39	10	
<b>NEW</b> GG4RL110B10		4.1	1	1.7	1	4	50	10	
<b>NEW</b> GG4RL110B15		4.1	1.5	1.7	1	4	50	10	
<b>NEW</b> GG5RL115B10		5.1	1	2.3	1.2	5	50	15	
<b>NEW</b> GG5RL115B15		5.1	1.5	2.3	1.2	5	50	15	
<b>NEW</b> GG5RL115B20		5.1	2	2.3	1.2	5	50	15	
<b>NEW</b> GG6RL115B10		6.1	1	2.8	1.4	6	50	15	
<b>NEW</b> GG6RL115B15		6.1	1.5	2.8	1.4	6	50	15	
<b>NEW</b> GG6RL115B20		6.1	2	2.8	1.4	6	50	15	
<b>NEW</b> GG8RL122B10		8.1	1	3.8	1.7	8	60	22	
<b>NEW</b> GG8RL122B15		8.1	1.5	3.8	1.7	8	60	22	
<b>NEW</b> GG8RL122B20		8.1	2	3.8	2.6	8	60	22	

**GK\_R**  新品上市  
New Arrival

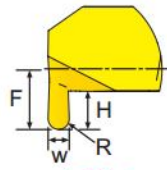
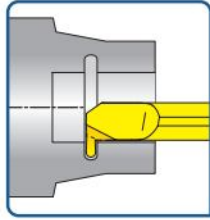

圖解 A  
Detail A

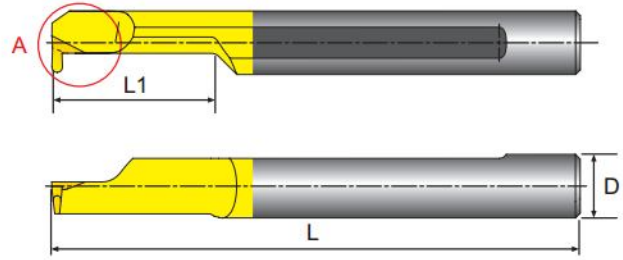

寸法 Dimension(mm)

產品型號 Model No	在庫 Stock	加工徑 Min Bore Dia	R	F	H	D	L	L1	W	價格 Price
<b>NEW</b> GK4RL110R05		4.1	0.5	1.7	1	4	50	10	1	
<b>NEW</b> GK4RL110R075		4.1	0.75	1.7	1	4	50	10	1.5	
<b>NEW</b> GK5RL115R05		5.1	0.5	2.3	1.2	5	50	15	1	
<b>NEW</b> GK5RL115R075		5.1	0.75	2.3	1.2	5	50	15	1.5	
<b>NEW</b> GK5RL115R10		5.1	1	2.3	1.2	5	50	15	2	
<b>NEW</b> GK6RL115R05		6.1	0.5	2.8	1.6	6	50	15	1	
<b>NEW</b> GK6RL115R075		6.1	0.75	2.8	1.6	6	50	15	1.5	
<b>NEW</b> GK6RL115R10		6.1	1	2.8	1.6	6	50	15	2	

GF\_L

新品上市  
New Arrival

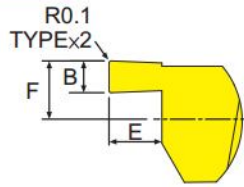
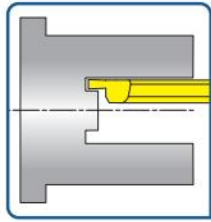

圖解 A  
Detail A

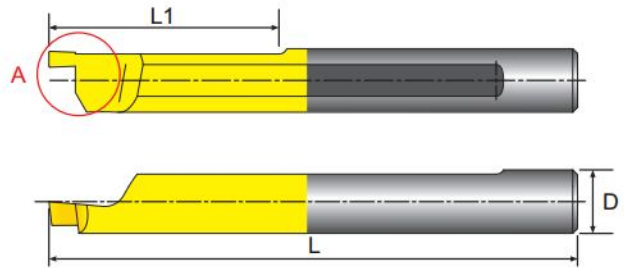

寸法 Dimension(mm)

產品型號 Model No	在庫 Stock	加工徑 Min Bore Dia	B	F	E	D	L	L1	價格 Price
<b>NEW</b> GF4LL115B075		5	0.75	1.75	1.2	4	50	15	
<b>NEW</b> GF4LL115B10		5	1	1.75	1.5	4	50	15	
<b>NEW</b> GF4LL115B15		5	1.5	1.75	2.8	4	50	15	
<b>NEW</b> GF5LL122B075		6	0.75	2.25	1.2	5	50	22	
<b>NEW</b> GF5LL122B10		6	1	2.25	1.5	5	50	22	
<b>NEW</b> GF5LL122B15		6	1.5	2.25	2.5	5	50	22	
<b>NEW</b> GF5LL122B20		6	2	2.25	3.8	5	50	22	
<b>NEW</b> GF6LL122B10		8	1	2.75	1.5	6	50	22	
<b>NEW</b> GF6LL122B15		8	1.5	2.75	2.5	6	50	22	
<b>NEW</b> GF6LL122B20		8	2	2.75	3	6	50	22	
<b>NEW</b> GF6LL122B25		8	2.5	2.75	4.8	6	50	22	
<b>NEW</b> GF6LL130B30		8	3	2.75	6	6	60	30	
<b>NEW</b> GF8LL122B25		10	2.5	3.75	3.5	8	60	22	

GF\_R

新品上市  
New Arrival

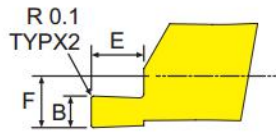
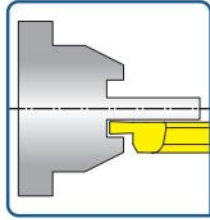

圖解 A  
Detail A

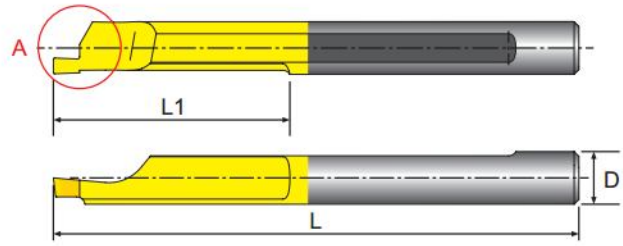

寸法 Dimension(mm)

產品型號 Model No	在庫 Stock	加工徑 Min Bore Dia	B	F	E	D	L	L1	價格 Price
NEW GF4RL115B075		5	0.75	1.95	1.2	4	50	15	
NEW GF4RL115B10		5	1	1.95	1.5	4	50	15	
NEW GF4RL115B15		5	1.5	1.95	2.8	4	50	15	
NEW GF5RL122B075		6	0.75	2.45	1.2	5	50	22	
NEW GF5RL122B10		6	1	2.45	1.5	5	50	22	
NEW GF5RL122B15		6	1.5	2.45	2.5	5	50	22	
NEW GF5RL122B20		6	2	2.45	3.8	5	50	22	
NEW GF6RL122B10		8	1	2.95	1.5	6	50	22	
NEW GF6RL122B15		8	1.5	2.95	2.5	6	50	22	
NEW GF6RL122B20		8	2	2.95	3	6	50	22	
NEW GF6RL122B25		8	2.5	2.95	4.8	6	50	22	
NEW GF6RL130B30		8	3	2.95	6	6	60	30	
NEW GF8RL122B25		10	2.5	3.95	3.5	8	60	22	

GD\_R

新品上市  
New Arrival

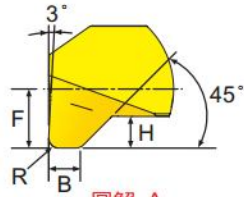
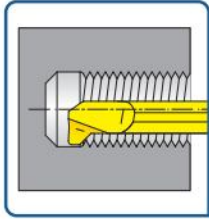

圖解 A  
Detail A

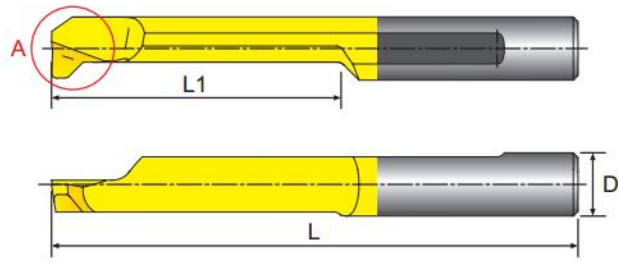

寸法 Dimension(mm)

產品型號 Model No	在庫 Stock	加工徑 Min Bore Dia	B	F	R	H	D	L	L1	價格 Price
<b>NEW</b> GD4RL118R05		4.1	1.5	1.8	0.5	0.8	4	50	18	
<b>NEW</b> GD5RL124R05		5.1	1.5	2.3	0.5	1.2	5	50	24	
<b>NEW</b> GD6RL127R05		6.1	1.5	2.8	0.5	1.4	6	60	27	

GZ\_R  新品上市  
New Arrival

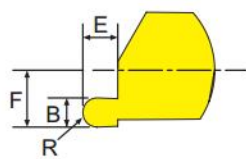
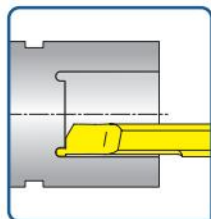

圖解 A  
Detail A

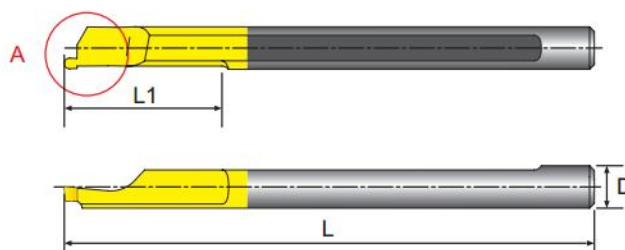

寸法 Dimension(mm)

產品型號 Model No	在庫 Stock	加工徑 Min Bore Dia	B	R	F	E	D	L	L1	價格 Price
<b>NEW</b> GZ4RL115R05		5	1	0.5	1.95	1.2	4	50	15	
<b>NEW</b> GZ4RL115R075		5	1.5	0.75	1.95	1.5	4	50	15	
<b>NEW</b> GZ5RL122R05		6	1	0.5	2.45	1.2	5	50	22	
<b>NEW</b> GZ5RL122R075		6	1.5	0.75	2.45	1.5	5	50	22	
<b>NEW</b> GZ5RL122R10		6	2	1	2.45	2.5	5	50	22	
<b>NEW</b> GZ6RL122R05		8	1	0.5	2.95	1.2	6	50	22	
<b>NEW</b> GZ6RL122R075		8	1.5	0.75	2.95	1.5	6	50	22	
<b>NEW</b> GZ6RL122R10		8	2	1	2.95	2.5	6	50	22	